



A CLOSED LOOP OPERATION OF THREE PHASE SINGLE STAGE MULTILEVEL INVERTER WITH FLYING CAPACITOR FOR PFC BY FEED FORWARD ERROR CORRECTION

Sayali A Jawale¹, M.Venkateswara Reddy²

¹Sayali A Jawale is Student of ME (Power Electronics & Drives) of R H Sapat College
Pune University,(India)

²M. Venkateswara Reddy Master of Engineering (Ph.D.) pune university, (India)

ABSTRACT—A closed loop operation of Three Phase Single Stage Multilevel Inverter with Flying Capacitor for PFC by Feed Forward Error Correction .A Feed Forward Correction of Three Phase Single Stage multilevel Inverter gives the better efficiency at light load condition and corrected the power factor by feed forward correction method. In this paper operating modes of converter is also explained with a slandered modulation scheme. And checked the feasibility of proposed converter for power factor correction by open loop designed by simulation results.

Keywords:- — *Multilevel Inverter topology,PWMstrategy,Power Factor Correction*

I. INTRODUCTION

In power system because of distribution generation it creates a problem like a power quality problem and harmonic distortion. Ac-dc power supply need to be implemented with some sort of power factor correction to minimizes the harmonic distortion in system. There are so many power factor correction techniques but having drawbacks as following:-

1. Power factor requirement by nonlinear load is restoration of distorted waveform and this is done by the filters .filters removed the harmonic content and make waveform sinusoidal like linear load device, but passive filters utilizes the high rating inductor and capacitor having a high frequency and as the harmonic content increases to eliminate numbers of filters increases this makes component bulky.
2. As size of component increases it increases the total cost of system is expensive and it used in a limited numbers of application.
3. The boost converter used for the power factor correction but to perform function like current shaping and output voltage regulation this is the main drawback that is bandwidth of the output voltage regulation is limited to few hertz.
- 4.Two stage converters is used for PFC correction method but having drawback of required implementation of

separate AC-DC module for each phase, which increase in cost and create problem of synchronization with each module.

5. The converter output current is discontinuous causes very high output ripple. Secondary diodes with high peak current ratings and large output capacitors to filter the ripple, so large input filters are needed.

The multilevel inverter uses the lower voltage sources to produced desired alternating voltage level in stepped form. Multilevel inverter topologies are Multilevel Diode Clamped/Neutral Point Inverter, multilevel capacitor clamped inverter, Cascaded Multicell Inverter. A closed loop operation of Three Phase Single Stage Multilevel Inverter with Flying Capacitor for PFC by Feed Forward Error Correction are used to mitigates this drawback also the proposed converter is advance than the previously proposed open loop multilevel inverter[2].

In this paper A closed loop operation of Three Phase Single Stage Multilevel Inverter with Flying Capacitor implemented with the slandered multicarrier PWM modulation, which gives the better results as compare to the previously proposed open loop multilevel inverter with slandered phase shift modulation. Multilevel inverter is very important converter structure in power electronics sector. The operation of the converter is explained, the new converter with flying capacitor designed is discuss for new circuit and confirmed with the simulation results and observed the harmonic content at output side of inverter. The proposed system consist of the proposed system consists of multilevel inverter with the flying capacitor which gives better efficiency and reduced harmonic content.

II. MULILEVEL INVERTERS

A multilevel inverter provides alternating voltage level at the output using multiple lower level DC voltages as an input. The inverters which produce an output voltage or a current with level either 0 or +-V is known as two level inverters. [8] The unique structure of multilevel voltage source inverters allows them to reach up to the high voltages without the use of transformers or series-connected synchronized-switching devices with low harmonics. The harmonic content of the output voltage waveform decreases significantly the most important topologies capacitor-clamped. Multilevel inverter is an array of power semiconductors and capacitor voltage sources, the output which generate voltages with stepped waveforms. With the commutation switches add the capacitor voltage to reach high voltage at the output.

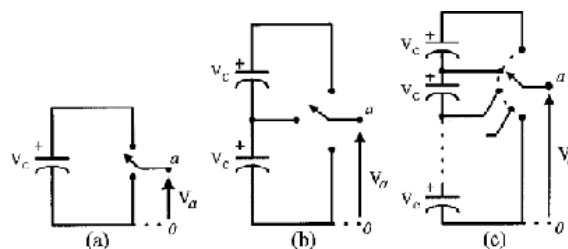

Fig 1. One phase leg of an inverter with (a) two levels (b) three level and(c) N levels. [7]

The attractive features of a multilevel converter can be briefly summarized as follows.

1. Multilevel converters not only can generate the output voltages with very low distortion, but also can reduce the dv/dt stresses; electromagnetic compatibility (EMC) problems can be reduced and also Multilevel converters produce smaller CM voltage; therefore, the stress in the bearings of a motor

connected to multilevel motor drive can be reduced. Furthermore, CM voltage can be eliminated by using advanced modulation strategies

2. Input current: Multilevel converters can draw input current with low distortion.
3. Switching frequency: Multilevel converters can operate at both fundamental switching frequency and high switching frequency PWM. It should be noted that lower switching frequency usually means lower switching loss and higher efficiency.

III. CONVERTER OPERATION

A closed loop operation of Three Phase Single Stage Multilevel Inverter with Flying Capacitor for PFC by Feed Forward Error Correction with multicarrier PWM is presented to improve efficiency of the converter. Flying capacitors are connected in series to inject the voltage in phase at different modes of operation. The converter is implemented with the standard phase shift modulation method, the waveform for the converter are shown in Fig the proposed converter is divided into two part one is rectifier unit and one is inverter unit but are coupled with the mutually coupled inductors. That mutually coupled inductors are nothing but the transformer which act as the “magnetic switches”. The main aim is to cancel out the DC bus voltage so voltage appears across the diode bridge output is zero. The mutually coupled inductor 1 cancels out the DC bus voltage when switches S1 and S2 are conducts so, voltage appears across the diode bridge output is zero and current in input inductors rises L_{a1}, L_{b1}, L_{c1} .

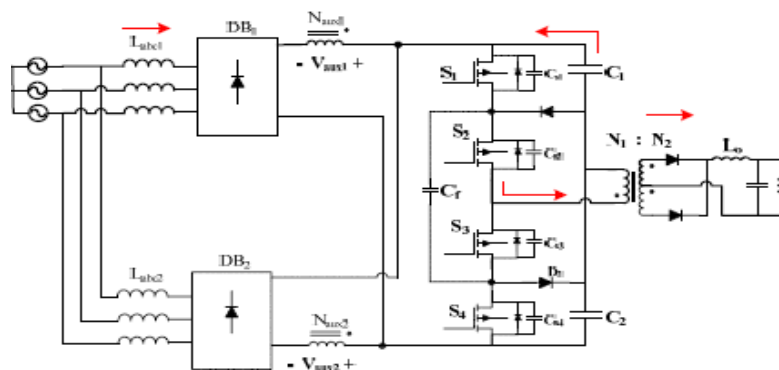

Fig2:- An three-phase three-level converter with a multilevel inverter [1]

When S3 and S4 are conducts the mutually coupled inductor 2 cancels out the DC bus voltage at the output of Diode Bridge 2 and voltage becomes zero and it causes rise in input inductor current $L_{a2}, L_{b2},$ and L_{c2} .

When there is no voltage across the coupled inductors, the total voltage across the DC bus capacitors appears at the output of the diode bridges and the input currents falls since this voltage is greater than the input voltage. If the input currents are discontinuous, the input current will be sinusoidal and in phase with the input voltages. The modes of operation of converter during each half cycle has explained in this paper having modes of operation mode1, mode2, mode3, mode4 and mode5,6,7,8.

The converter is implemented with the standard phase shift modulation method, the waveform for the converter are shown in Fig the proposed converter is divided into two part one is rectifier unit and one is inverter unit but are coupled with the mutually coupled inductors. That mutually coupled inductors are nothing but the

transformer which act as the “magnetic switches”. The main aim is to cancel out the DC bus voltage so voltage appears across the diode bridge output is zero. The mutually coupled inductor 1 cancels out the DC bus voltage when switches S1 and S2 are conducts so, voltage appears across the diode bridge output is zero and current in input inductors rises La1,Lb1,Lc1 .

When S3 and S4 are conducts the mutually coupled inductor 2 cancels out the DC bus voltage at the output of Diode Bridge 2 and voltage becomes zero and it causes rise in input inductor current La2, Lb2, and Lc2.

When there is no voltage across the coupled inductors, the total voltage across the DC bus capacitors appears at the output of the diode bridges and the input currents decreases as the voltage is greater than the input voltage. If the input currents are discontinuous, the envelope of the input current will be sinusoidal and in phase with the input voltages. The modes of operation of converter during each half cycle has explained in this paper having eight modes of operation mode1, mode2, mode3, mode4 and mode5,6,7,8.

The closed loop system maintains the output stability and help to reduce harmonic content and increase the overall efficiency of the converter. In proposed system the actual voltage and current at the input side is compare with the converter output voltage and current. Based on the error signal controller controls the switching frequency of MOSFET by using multicarrier PWM. In multicarrier PWM In the carrier signal compare with the reference triangular waveform which produces the pulses.

III. MODES OF OPERATION

During this interval, switches S1 and S2 are ON. in this mode the energy is transfer from DC bus capacitor to the output load. the voltage appears across the auxiliary winding 1 is equal to the DC bus voltage but opposite in polarity. So it cancels out the voltage at Diode Bridge and output voltage at diode bridge is zero and the input current of the inductors La1, Lb1, Lc1 are rise.

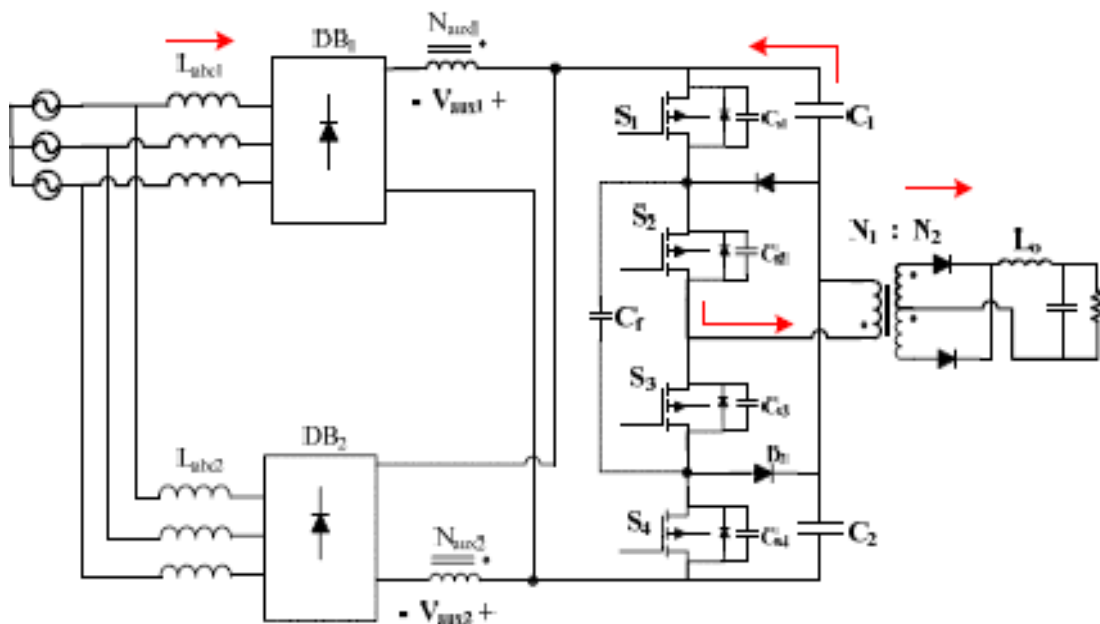

Fig 3. Mode 1(t0<t<t1)

Mode 2($t_1 < t < t_2$):-

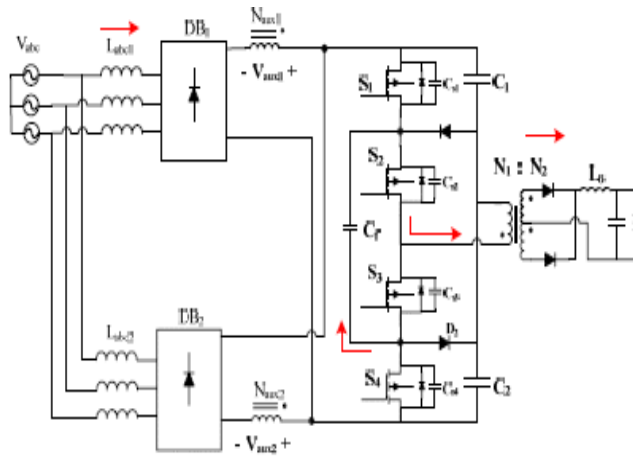

Fig 4. Mode 2($t_1 < t < t_2$)

In this mode S1 is OFF and S2 remains ON. Cs1 charges and Cs4 is discharges through the flying capacitor this process continues uptill the voltage across the S4 is reduced to the zero .in this mode the energy transfer to the inductor in mode 1 is return back to the DC bus capacitor this mode continue up to the S4 turn ON.

Mode 3($t_2 < t < t_3$):-

In mode 3 S1 is OFF and S2 remains ON. energy stored into the inductor is continuously transfer to DC bus capacitor .this is a freewheeling mode in which the primary auxiliary winding current is flowing through the D1 and S2 .

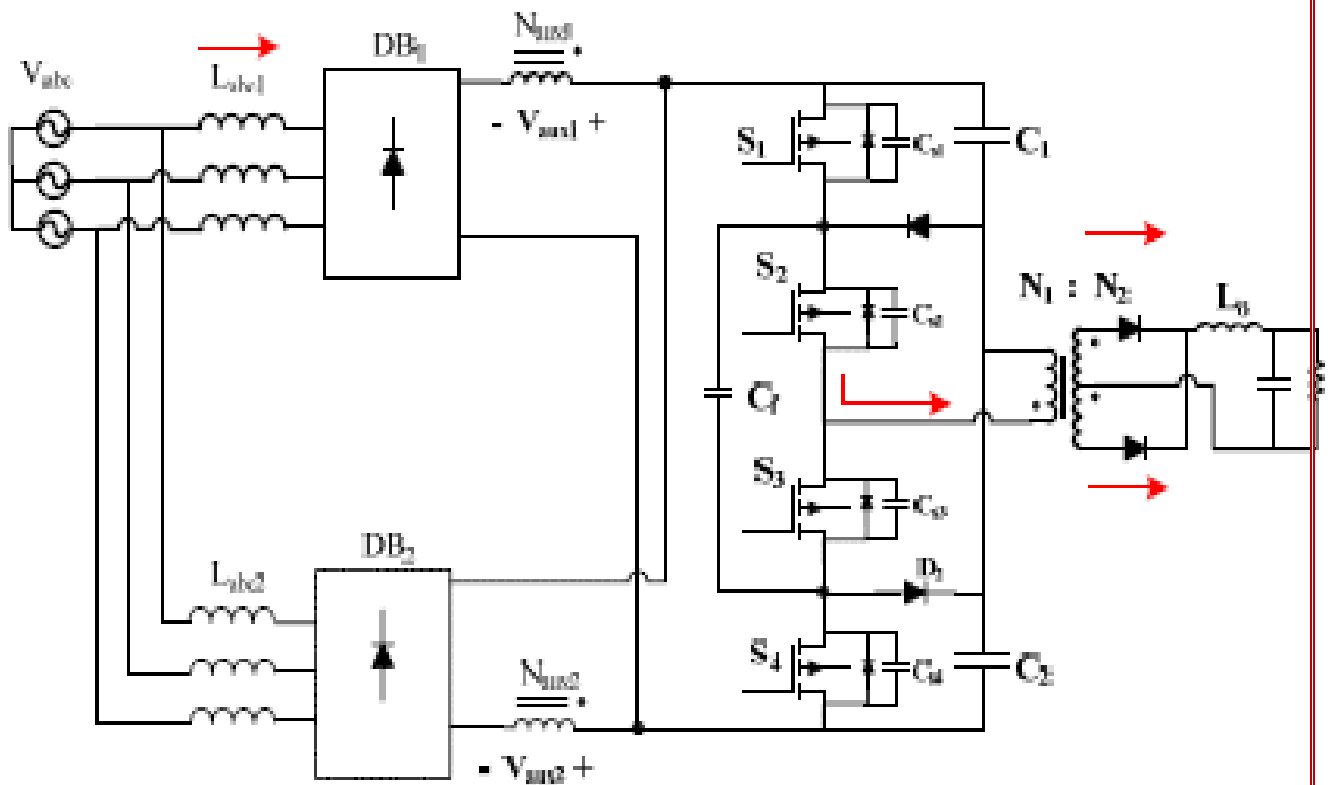

Fig 5. Mode 3($t_2 < t < t_3$)

Mode 4($t_3 < t < t_4$):-

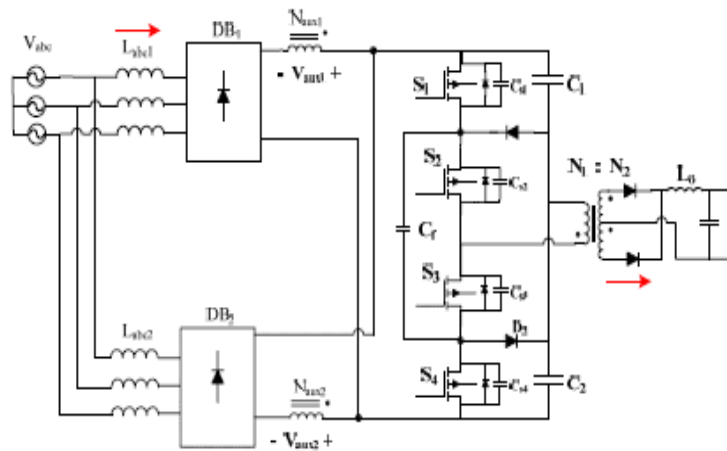

Fig 6. Mode 4($t_3 < t < t_4$)

during the mode ($t_3 < t < t_4$) S1 and S2 are OFF . the energy stored in inductor is continuously transfer to the DC bus capacitor the primary current of transformer is discharge through the Cs3 .when it discharge through Cs3 current will flow through the path of diodes of S3 .this current charges the C2 through diode of S3 and S4.

Mode 5($t_4 < t < t_5$):-

In this mode, S3 and S4 are ON and energy flows from capacitor C2 to the load. The voltage appears across the auxiliary winding 2 is equal to the DC bus voltage but opposite in polarity so voltage appears across the diode bridge is zero. And inductor current La2, Lb2, Lc2 are rise.

This mode ends when the total energy stored from the inductor is completely transferred to the DC bus capacitor.

Mode 6($t_5 < t < t_6$):-

In this mode, S3 is ON and S4 OFF and primary current start flowing through the diode d1 and S3.the energy stored into inductor L2 start transferring into the DC bus capacitor.

Mode 7($t_6 < t < t_7$):-

In this mode, S3,S4 are OFF and transformer current charges the capacitor C1 through the body of S1 and S2.energy stored in inductor starts transferring to DC bus capacitor.

Mode 8($t_7 < t < t_8$):-

In this mode, In this mode,S1and S2are ON. In this mode energy completely transfer to the dc bus capacitor to the load. At T8 time end of the switching cycle and new cycle begins.

The input current of the inductors are the sum of i_{L1} and i_{L2} having a discontinuous current. However by setting the appropriate values of the inductors, that two inductor current overlap to each other so that it produces the continuous output current.

In this paper the converter is proposed with phase shift PWM used to generate a gating pulse. In this modulation method gate pulses generated by comparing the triangular wave with the sinusoidal wave.

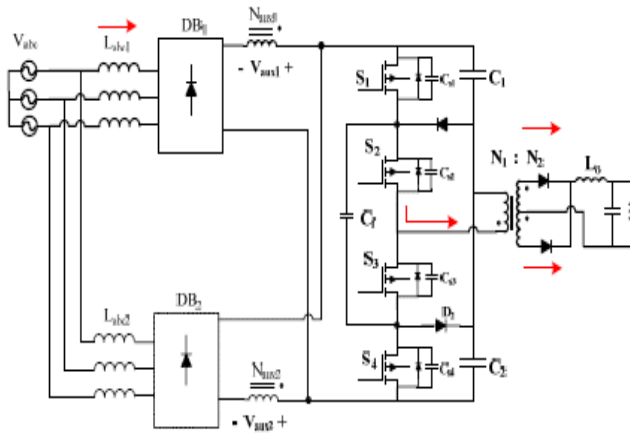

Fig 5. Mode 6 ($t_4 < t < t_5$)

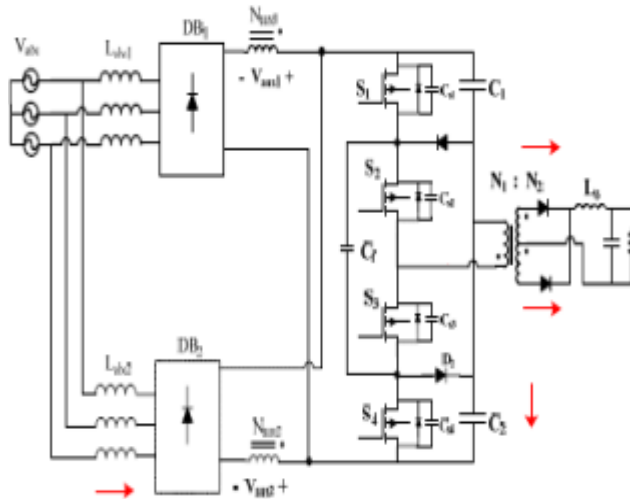

Fig 6. Mode 6 ($t_5 < t < t_6$)

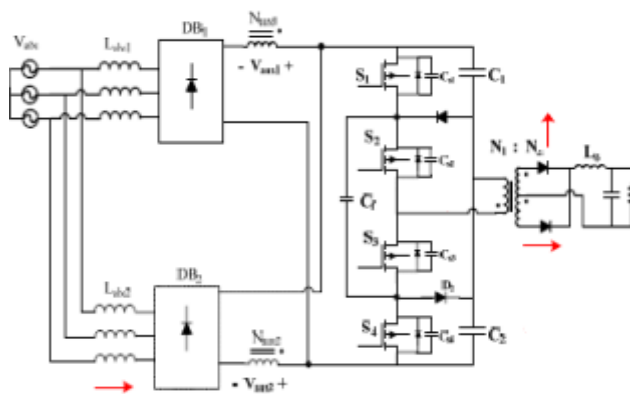

Fig 7. Mode 7 ($t_6 < t < t_7$)

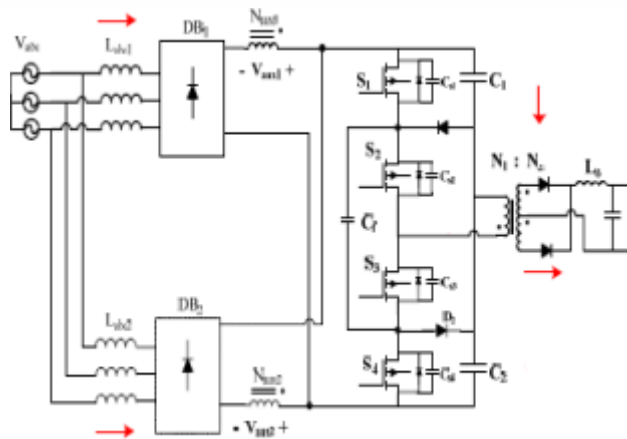

Fig 8. Mode 8 ($t_7 < t < t_8$)

Switching states				Vout
S1	S2	S3	S4	
On	On	Off	Off	VS
Off	Off	On	On	-VS
On	Off	On	Off	0
Off	On	Off	On	0
Off	Off	Off	Off	-VS
Off	Off	Off	Off	VS

++Table no1. Switching state of switches.

IV. CONVERTER PARAMETER

The main parameter of the converter is output inductor, transformer ratio, input inductor, flying capacitor by selecting the appropriate values of this parameter converter efficiency gets increase[1].

4.1 output inductor L_o

The output inductor L_o is gives the continuous converter output current. When converter operating with the maximum input voltage and minimum load then converter produces the continuous output current for all operating condition

4.2 input inductor L_{in}

Input current is the summation of i_{L1} and i_{L2} which both are discontinuous by selecting the appropriate values of $L1 (L_{a1}, L_{b1}, L_{c1})$ and $L2(L_{a2}, L_{b2}, L_{c3})$ such that that two current will overlap each other and input current is made.

4.3 flying capacitor

The flying capacitor is charge up to the half of the dc bus voltage, when this converter operated with phase shift PWM method Fig, by giving a gating pulse C_f made connect and disconnect from the converter, such as $S1$ is turned OFF to start mode 2 and when $S4$ is turned OFF during the equivalent mode. The flying capacitor stored the charge and connected in series with the converter to inject the voltage in the phase.

$$C_f = \frac{I_o \cdot \Delta t}{\Delta V_{cf}}$$

ΔV_{cf} (1) Equation no (1) gives the relation between the C_f and ripple voltage

Where,

C_f = flying capacitor

V_{cf} = voltage of flying capacitor

V. SIMULATION AND RESULT

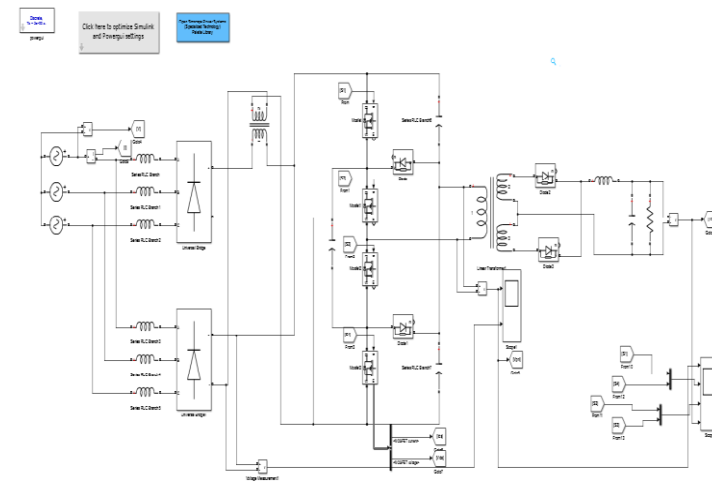

Fig 7. An three phase three level converter Circuit

The simulation circuit of the three phase three level converter Circuit is shown in the Fig 7 shows the simulation result of output waveform of the transformer and Fig 9 shows the simulation result of DC voltage and gate pulses.

The power factor correction is done by the input current and voltage waveform by correcting the voltage value by injecting and subtracting the voltage from the phase with the help of multilevel flying capacitor. phase difference between the waveform is zero, so it gives power factor correction.

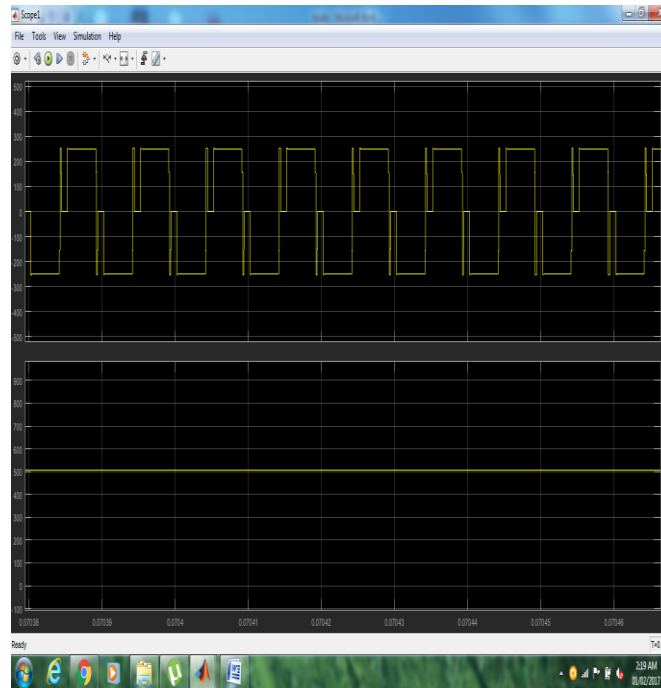

Fig 8. Shows the result of Transformer output

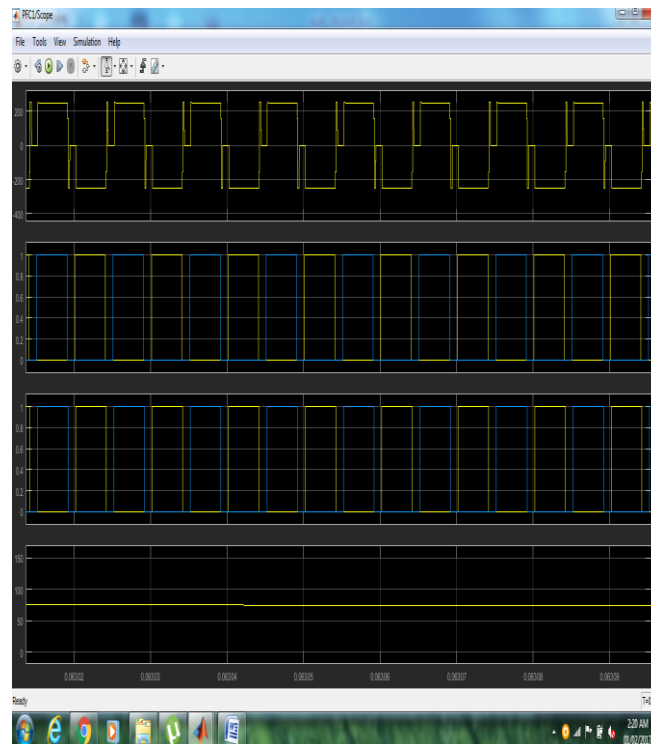

Fig 9. Shows the result of input DC voltage waveform of the converter and multilevel inverter



VI. CONCLUSION

A Feed Forward error Correction Of Three Phase Single Stage multilevel Inverter With Flying Capacitor For Power factor corrected using slandered phase shift pulse width modulation. In this paper operation of converter was explained with simulation results. Converter presented with different modes of operation and also Role of flying capacitor in converter is explained for power factor correction.

VII. REFERENCES

- [1] Mehdi Narimani, A New Interleaved Three-Phase Single-Stage PFC AC-DC Converter with Flying Capacitor, IEEE 2014 transaction on power electronics
- [2] H.S. Ribeiro and B.V. Borges, "New optimized full-bridge single-stage ac/dc converters," IEEE Trans. on Industrial. Elec., vol. 58, no. 6, pp. 2397-2409, 2011.
- [3] H. Sheng, F. Wang, and C.W. Tipton, "A fault-detection and protection scheme for three-level dc-dc converters based on monitoring flying capacitor voltage," IEEE Trans. Power Electron., vol. 27, no. 2, pp. 685–697, Feb. 2012.
- [4] N. Rocha, C. B. Jacobina, C.D. Santos, "Parallel connection of two single-phase ac-dc-ac three-leg converter with interleaved technique", IEEE IECON 2012, pp.639-644.
- [5] B. Tamyurek and D. A. Torrey, "—A three-phase unity power factor singlestage AC–DC converter based on an interleaved flybacktopology,|| IEEE Trans. Power Electron., vol. 26, no. 1, pp. 308–318, Jan. 2011.
- [6] J. M. Kwon, W. Y. Choi, and B. H. Kwon, "—Single-stage quasi-resonant flyback converter for a cost-effective PDP sustain power module,|| IEEE Trans. Ind. Electron., vol. 58, no. 6, pp. 2372–2377, Jun. 2011.
- [7] H. L. Cheng, Y. C. Hsieh, and C. S. Lin, "—A novel single-stage high-powerfactor AC/DC converter featuring high circuit efficiency,|| IEEE Trans. Ind. Electron., vol. 58, no. 2, pp. 524–532, Feb. 2011.
- [8] 1r.dharmaprakash, 2joseph henry- switching table based 2-level inverter and3-level diode clamped inverter, journal of theoretical and applied information technology 20th february 2014. vol. 60 no.2© 2005 - 2014 jatit&lls. all rights reserved.
- [9] José rodríguez, senior member, ieee, jih-sheng lai, senior member, ieee, andfangzhengpeng, senior member, ieeemultilevel inverters: a survey of topologies, controls, and applications ieee transactions on industrial electronics, vol. 49, no. 4, august 2002
- [10] Multilevel Inverter Topology Survey-Multilevel Inverter Topology surveythesis for the degree of master of science