



SPEED CONTROL AND MAXIMUM POWER POINT TRACKING OF SYNCHRONOUS GENERATORS IN A WIND FARM USING FUZZY CONTROLLERS

Tanuj Mishra¹, Shivani Mehta², Abhay Bhandari³

¹*Electrical Department, LPU, Phagwara, Punjab, India*

²*Electrical Department, DAVIET, Jalandhar, Punjab, India*

³*Electronics and Communication Department, LPU, Phagwara, Punjab, India*

ABSTRACT

Fundamental target of this paper is to investigate the execution of a wind farm by utilizing fuzzy controls for improving the efficiency. This work deals with the execution of a wind farm by using fuzzy control system for productivity advancement and execution. A wind farm comprising of multiple wind turbines associated with a three fuzzy control system which feeds power for distribution system. One fuzzy control is being used for detecting the change in the speed of the synchronous generator with respect to the wind speed for extracting the maximum power out of it. Secondary Fuzzy controller used to detect flux for improving the efficiency during light load. Third fuzzy controller gives vigorous control against turbine oscillation due to wind vortex. The comparison graph is to be designed between the two systems using FLC and without fuzzy system.

Keywords— *Fuzzy, MPPT, Synchronous Generator, Wind, Wind farm.*

I. INTRODUCTION

The force of the airstream has been used for no less than 3000 years. While waiting for the mid-twentieth century wind power was utilized to give machine-driven energy to pump water or to pound grain. Amid the most recent span of the twentieth century, overall wind limit multiplied roughly like clockwork. The budget of power from wind control has tumbled to around one 6th of the cost in the mid-1980s. Wind energy can possibly assume a critical part in future energy supply in numerous regions of the world. Inside the previous 12 years, wind turbine innovation has come to an exceptionally solid and complex level. The developing overall market will prompt further upgrades, for example, bigger wind turbines or new framework applications (e.g. offshore wind farms). These upgrades will prompt further cost decreases and in the medium term wind vitality will have the capacity to contend with traditional fossil fuel control era innovation.

II. WIND ENERGY

Wind vitality is essentially a type of sunlight based vitality and brought on because of the uneven warming of the environment, the anomalies of the world's surface, and revolution of the earth cause winds[1]. Wind vitality

can be used for the era of electrical Energy. The fundamental preferred standpoint of wind Energy is that it is a renewable wellspring of energy and is absolutely perfect. Wind Energy can possibly assume an imperative part in future Energy supply in numerous territories of the world.

WECS

The power contained in the wind is given by the active vitality of the streaming air mass per unit time, that is

$$P_{\text{air}} = \frac{1}{2}(\text{air mass per unit time}) (\text{wind velocity})^2$$

$$= \frac{1}{2}(\rho AV^3)$$

Although above equation[2] gives the power accessible in the airstream, the power exchanged to the wind turbine rotor is decreased by the power coefficient, C_p . A most extreme estimation of C_p is characterized by as far as possible, which expresses that a turbine can never extricate over 59.3% of the power from an air stream. As a general rule, wind turbine rotors have most extreme C_p values in the range 25-45%.

In the event that the pressure increments by 10% and the temperature diminishes by 15%, the air thickness will increment about 30%. Fig. 1 demonstrates the impact of air density on the power curves. At the point when the air thickness builds, the most extreme mechanical power yield expands, which brings about moving the greatest power point line[3]. Different methods have been proposed to adapt to the varieties in the wind speed to guarantee high execution and unflinching yield for the wind energy system[4]. The change in the power output with respect to wind can be solved by adopting fuzzy logic control. In this paper three fuzzy logic controllers have been employed to control the speed of the synchronous generators used in a wind farm and yields maximum power output.

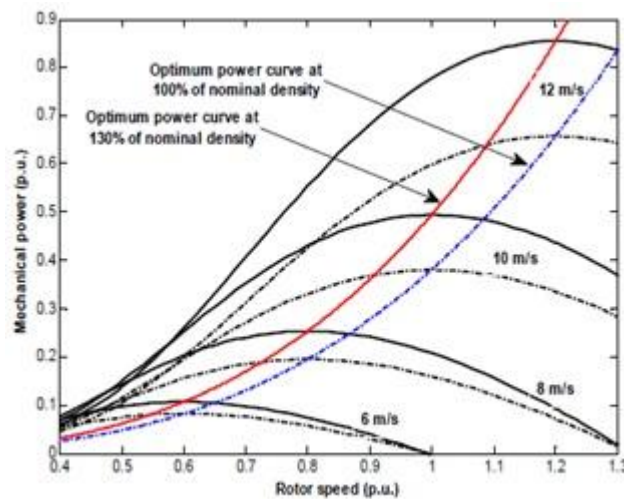

Fig.1 The effect of air density on the power curves[2]

IV. FUZZY LOGIC CONTROLLERS

Fuzzy logic standards have been utilized as it is an intense and flexible apparatus to speak to uncertain and dubious data just. It helps in displaying the troublesome and unmanageable issues. The fundamental goal is to actualize fuzzy logic regulator to enhance the execution of the framework and concentrate greatest power from the generator for the variable wind generation. There are three types of Fuzzy logic controllers out of which Mamdani controllers are decide based controllers that utilize "if-then" arrange for the control procedure[5]. In this arrangement, a few factors could be utilized either in condition or conclusion side of the "if-then" rules. Fuzzy Logic is a critical thinking governor that fits usage in system running from basic, little, implanted small scale controllers to extensive, arranged, multi-channel PC or workstation-based information procurement and control system. It can be actualized in hardware, programming, or a mix of both. FL gives a basic approach to land at-a distinct conclusion based upon obscure, questionable, loose, uproarious, or missing info data. Fuzzy logic is an augmentation of Boolean logic managing the idea of incomplete truth while established logic holds that everything can be communicated in binary terms (0 or 1, dark or white, yes or no), fuzzy logic replaces Boolean truth values with degrees of truth. Degrees of truth are frequently mistaken for probabilities, in spite of the fact that they are reasonably unmistakable, in light of the fact that they require not mean 100%. Fuzzy Logic takes into account set membership values between and including 0 and 1, shades of grey and in addition highly contrasting, and in its linguistic shape, loose ideas like "slightly", "very" and "extremely". In particular, it permits fractional participation in a set. It is identified with fuzzy sets and plausibility hypothesis.

V. MAXIMUM POWER POINT TRACKING

It could be seen from the graph as shown in fig. 2 that for a specific wind speed FLC capacity is to hunt the generator speed until the framework settles down at the most extreme power yield condition. For wind speed V_{w4} in fig. 2, the yield power will be at A if the generator speed is $\omega r1$. FLC will modify the speed and reaches to speed $\omega r2$ where the yield power is most extreme at B. In the event that the wind speed increments to V_{w2} , the yield power will hop to D, and afterward FLC will convey the working point to E via seeking the speed to $\omega r4$.

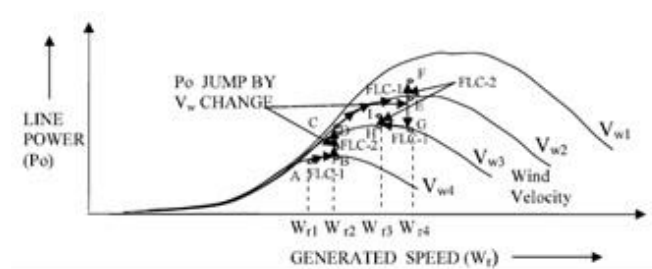

Fig. 2 Use of FLC1 and FLC2 in MPPT [6].

Comparative is the situation of reduction in wind speed. With an augmentation (or decrement) of speed, the relating addition (or decrement) of yield power is assessed[6]. The controller works for every unit premise so that the reaction is uncaring to framework factors and the calculation are all inclusive to any framework.

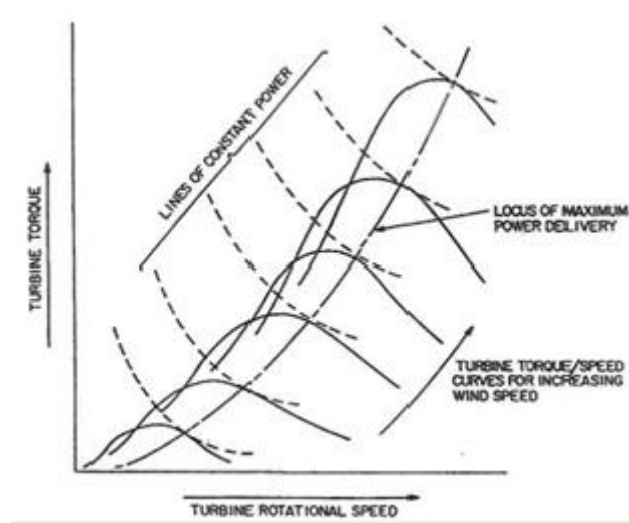

Fig. 3 Family of torque/ speed curves for a wind turbine [7].

Place over on the group of bends is an arrangement of steady power lines (spotted) showing the area of greatest power conveyance for each wind speed as shown in fig 3. This implies, for a specific wind speed the turbine speed is to be changed to get the most extreme power yield, and this point goes amiss from greatest torque point as demonstrated[7]. This implies at diminished speed light load consistent state conditions, generator productivity can be enhanced by programming flux.

VI. WIND FARM WITHOUT FUZZY CONTROL

Simulink model of wind farm has been designed without using any optimization technique. A simplified design of wind farm as shown in fig. 4 is suggested in which the variation in output power is observed with respect to the deviation in the wind energy.

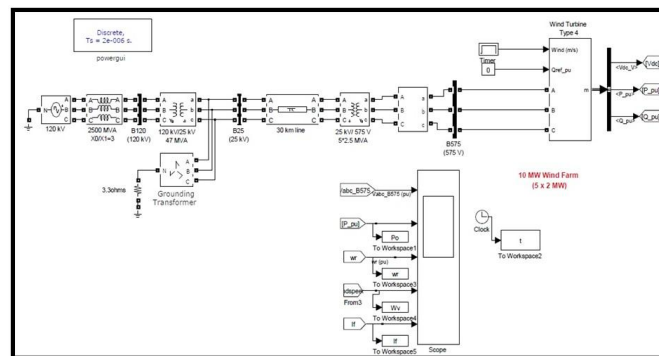

Fig. 4 Simulink model for 10 MW wind farm without fuzzy logic control

A wind farm is designed having capacity of 10 MW which consist of 2 MW wind turbines which are five in numbers connected to a three phase load source and exports power for distribution purpose. Synchronous generators are used in wind turbines which consist of variable speed pitch control system and an AC to DC and DC to AC PWM converter. Theses converters contains IGBT devices. The stator winding is associated with the 60 Hz voltage source while the rotor is sustained at variable recurrence through the AC/DC/AC converter. This

innovation permits extricating most extreme vitality from the airstream for low speed of the wind by improving the turbine speed, while limiting mechanical weights on the turbine amid blasts of wind. In this case the airstream speed is kept up consistent at 15 m/s. But as per our objective variation in the flow of wind is added. The parameters of the synchronous generator are reported in the given Table I.

TABLE I. Synchronous Generator Parameter

S. No.	Parameters	Values
1	Nominal Power output	2 MW
2	Nominal Phase to phase voltage	575 Volt
3	Rotor resistance in p.u	0.006
4	Base frequency	60 Hz
5	Pair of poles	1
6	Inertia constant	0.62
7	Friction factor	0.01

The sample time used to discretize the model ($T_s=50$ microseconds) is determined in the initialization capacity of the model properties. The turbine control, the tip speed proportion λ and the C_p qualities are shown as capacity of wind speed. For a twist speed of 15 m/s, the turbine yield power is 1 pu of its evaluated control, the pitch-point is 8.7 degree and the generator speed is 1.2 pu. The result obtained from the output is displayed on the scope. The major concern is about the three main quantities i.e. Generator speed, power output, and flux current. As the wind flows variably the speed of the generator is increasing to its maximum value and decreases accordingly. The output is compared between generator speed and the turbine power output.

VII. WIND FARM WITH FUZZY CONTROL

The fundamental goal is to actualize fuzzy logic regulator to enhance the execution of the framework and concentrate greatest power from the generator for the variable wind generation. Three FLC regulators have been implemented in the wind farm model as shown in fig 5.

FLC1: This hunts the ideal generator speed so that the proficiency of the wind turbine is greatest. This one is fundamentally utilized for MPPT.

FLC2: This one generally reduces the generator rotor flux during light load condition which further enhances the efficiency of the System

FLC3: This one is basically used for the robust speed control for the oscillation produced due to the wind vortex. The function of all the three fuzzy logic controllers can be observed from the figure 5.

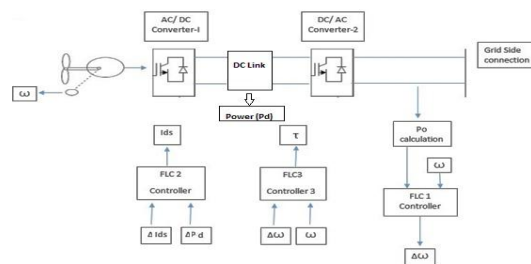

Fig. 5 Control system for Wind farm using Fuzzy controller

Fuzzy Logic Controller 1 (Generator speed following controller)

The function of the FLC1 is that for a specific wind speed this function will seek the speed of the generator until the framework stops at the most extreme power yield condition. The Simulink model for the FLC1 is shown in fig. 6.

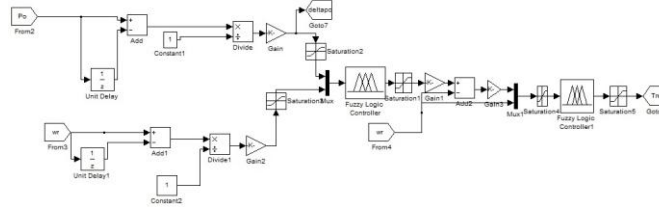

Fig. 6 Simulink model for FLC1 and FLC3

In the fig. 7 we can see that FLC1 will assess an increment (on the other hand decrement) of speed, the relating increment (or decrement) of yield power. In Fuzzy controller-1, there are two information variables at the input i.e. ΔP_0 and $L\Delta\omega_r$ and one output $\Delta\omega_r$ as shown in fig. 7

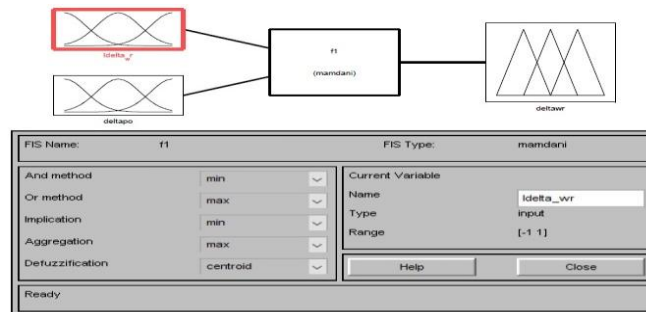

Fig. 7 fuzzy window for FLC1

Fuzzy Logic Controller 2 (Flux current controller)

The capacity of FLC - 2 is to program the machine rotor flux for light load effectiveness change. Simulink model for FLC2 regulator is shown in fig. 8

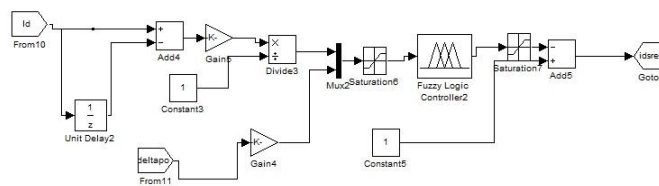

Fig.8 Simulink model for FLC2

The system power control $P_o(k)$ is examined and contrasted and the past esteem $P_o(k-1)$ to decide the augmentation ΔP_o . In expansion, the last excitation current decremented is audited. In FLC2, there are two input variables I_{delta} and $delta_po$ and one output variables $delta_ids$ as shown in fuzzy window in fig. 9.

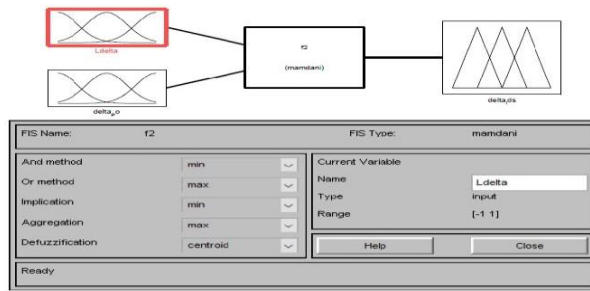

Fig. 9 Fuzzy window for FLC2

FLC3 (Generator Oscillatory Controller)

Simulink model for the FLC3 is shown in fig. 6. The input variables for the fuzzy controller are speed E_w and change in speed ΔE_w and output variable is ΔT_E . Both the speed change and error in speed are processed through the FLC3 and produce torque output component for current. This FLC controller works all the time.

VIII. SIMULATION OUTPUT

Without Fuzzy Controller simulation results

The figure 10 is the input, which is applied to the wind farm. The graph displays the deviation in the wind speed w.r.t time along with some turbulence added in the airstream speed. The behavior of the generator can be observed with respect to the wind speed input.

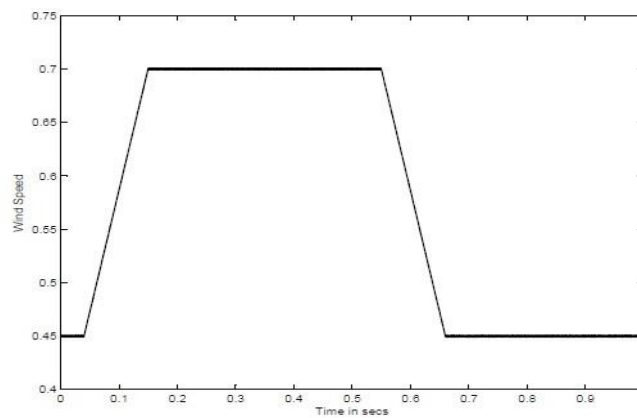

Fig.10 Wind speed Vs Time Graph

In figure 11 it can be seen that with the deviation in the wind velocity the speed (C_r) of the synchronous generator increased and effect of the turbulence can also viewed as speed is settled at constant after 60 secs. This turbulence in the speed of the synchronous generator affects the average output power. This behavior of the generator is judged under ideal load and fault condition is suggested. The DC voltage is managed at 1100 V and receptive power is kept at Zero Mvar.

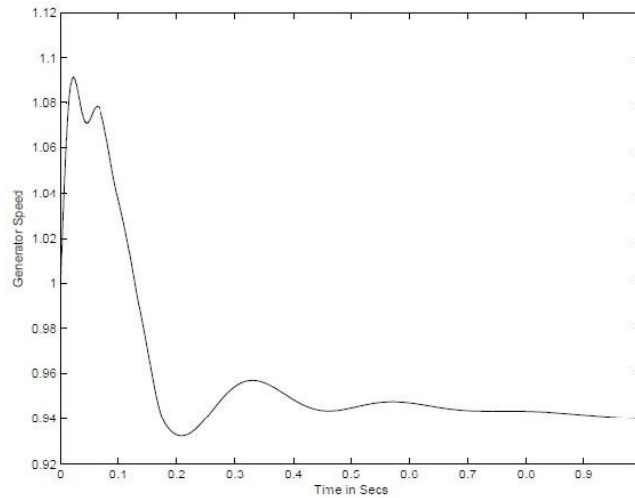

Fig. 11 Generator Speed Vs Time graph

From the figure 12 it can be seen that as per the speed of the generator the output power is not extracted to its extreme. Even it do not reaches to its maximum point. This outcome uncovers that for a specific generator speed, if the wind speed is expanded, it's relating turbine torque is additionally expanded. Due to which the output power is also increased.

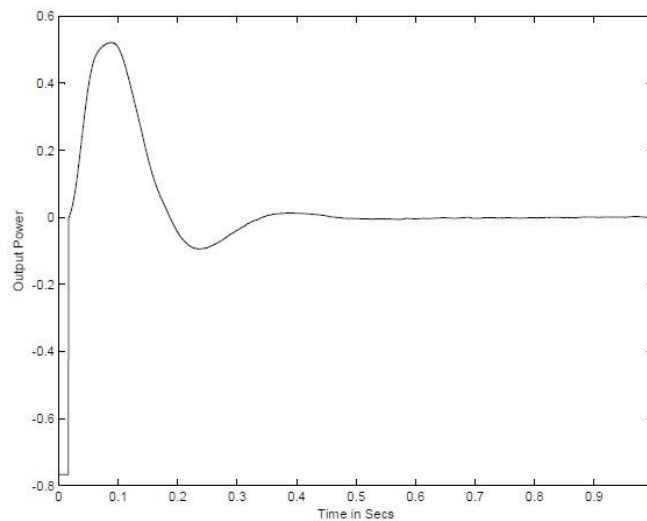

Fig. 12 Output Power Vs Time Graph

As per the above graph the average output power is low which gives rise to the poor efficiency of the wind farm. If we check the rotor flux current for this model it will show that during light load its value is more and results in increase in the losses. This further reduces the efficiency of the motor. The output graph for the same is shown in fig 13.

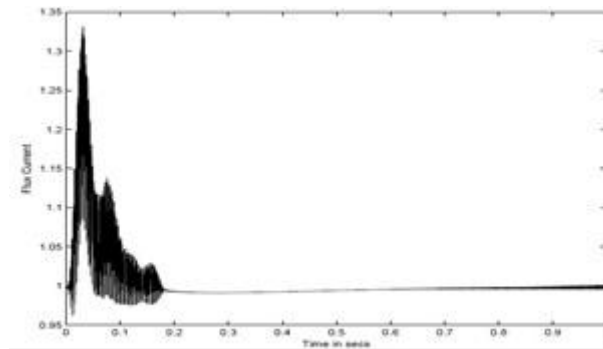

Fig. 13 Flux current Vs Time graph

With FLC Control Simulation Results

Table 2: Output results of Fuzzy Logic controller 1

Instructions	ΔW_r	ΔP_o	ΔW_r
State 1	0.0367	0.173	0.371
State 2	-0.205	-0.866	0.665
State 3	0.741	-0.866	-0.633
State 4	-0.509	0.866	-0.664

As per the table 2 shown above the change in the input variables gives rise to the corresponding change in the output variable as per the rules obtained for the FLC3. There are only four conditions taken in the table. These results easily defines that how FLC1 is working. If the change in the Power output P_o is Positive like 0.173 with the deviation in the generator speed ΔW_r than the speed will be incremented in the same positive direction like 0.371. Yield result uncovers that for a specific speed of generator, if the airstream is expanded its related turbine torque is additionally expanded. As we realize that if torque increased with speed than output power will increase. This outcome uncovers that for a specific speed of generator, if the airstream is expanded, its comparing turbine created power is likewise expanded. This can be approved from the fig. 14

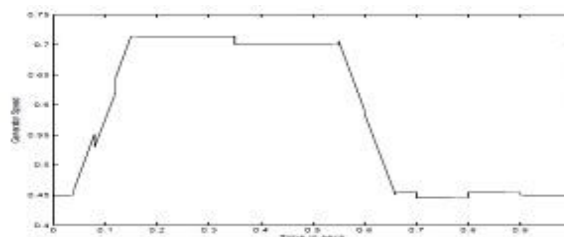

Fig. 14 Generator speed Vs Time

The yield power is obtained as per the result of the torque and eed so the change in the output power can be displayed as shown in figure 15.

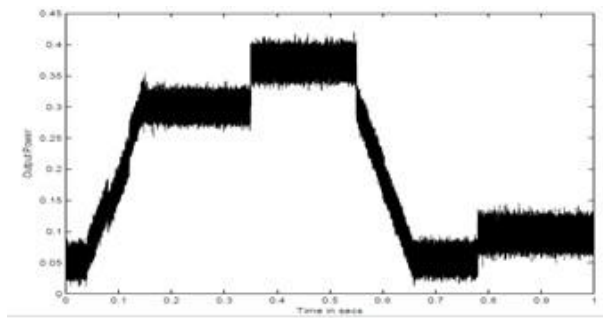

Fig. 15 Power output Vs Time

The variation in the generator speed is because of the airstream vortex added in the input. So as per the change in the wind speed we can easily observe how FLC1 is tracking the maximum output power. Whereas the change in the speed of the generator due to wind vortex is being attended by the FLC3 which regulates the torque current as per the change in the speed and speed error of the generator. Also it has been observed from the fig that during light load whenever the speed of generator drops FLC2 will regulate the flux current which will reduce the losses and overall efficiency will be improved which in turn increase the output power of the system. The regulation of the flux current is shown in the figure. 16

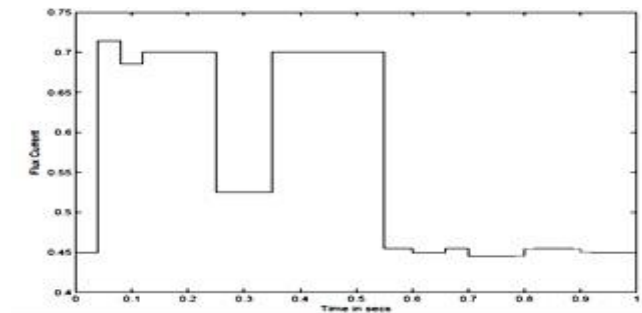

Fig. 16 Flux Current Vs Time

Power Output comparison between two systems

As per the outputs obtained for both the system one without using fuzzy and other using fuzzy analysis can be made. At any instant following values have been obtained for the different parameters under consideration as shown in the table 3.

Table 3: Simulink results for Wind Farm using Fuzzy Controller

S.No.	Time	Po	Wind Speed	Generator speed
1	0.365672	0.372939	0.699556466	0.7
2	0.365674	0.35038	0.699556466	0.7
3	0.365676	0.376547	0.699556466	0.7
4	0.365678	0.365655	0.699556466	0.7
5	0.36568	0.375612	0.699521971	0.7
6	0.365682	0.371302	0.699521971	0.7
7	0.365684	0.356592	0.699521971	0.7

The comparison chart between the power outputs of the two system comes out like the graph shown below. The action of all the fuzzy logic controllers can be visualized in the power output line obtained.

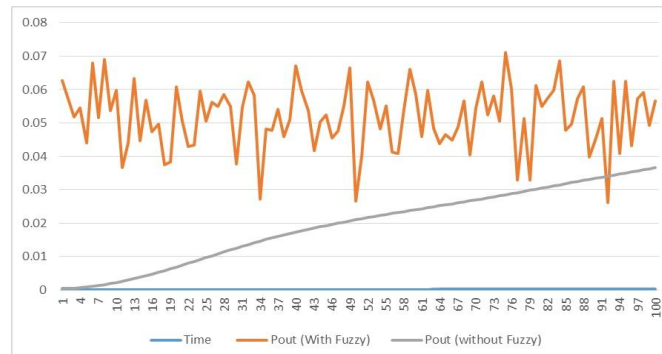

Fig.17 Power output comparison between fuzzy and without fuzzy system

X. DISCUSSIONS

From the graph as shown in fig. 17 it is visible that in a system where fuzzy is used, the search towards the maximum power output is going on with respect to the wind speed which in turns increases the average output power. In both the models the output results are compared with the same input which is the variable wind velocity as shown in fig. 10. FLC-Regulator 1 will monitor the generator and changes the speed with the adjustment in wind speed to concentrate greatest control. So as the speed of airstream increments, speed of generator is additionally expanded by primary fuzzy controller. As an aftereffect of which the line power is additionally expanded. Comparable is the case for the abatement in wind speed. Fuzzy logic controller 2 will reduce the losses in the machine which further increases the efficiency whereas Fuzzy logic controller 3 works all the time and results are visible.

XI. CONCLUSION

If we compare with fossil fuels and nuclear energy, wind energy conversion system is getting more consideration since it is most cost focused, natural perfect and ecofriendly power source. The fundamental issue which happens in the wind energy transformation is that the execution of the wind turbine is exceptionally subject to the force of wind. The FLC based Wind farm framework has been examined and Simulink exhibitions has been considered to approve all the hypothetical ideas. But before implementing the FLC system, a model is designed which is not utilizing the FLC system and its output is compared with the system model in which FLC control is utilized.

The fundamental target is to investigate the execution of the Wind Farm utilizing fuzzy control for improving the efficiency. For implementing this three FLC regulators are designed. The primary fuzzy controller looks on line the ideal speed so that the streamlined productivity of the wind turbine is most extreme. This regulator will continuously searches the generator speed to obtain the maximum power output. The secondary fuzzy regulator lineup the rotor flux by an online seek in order to enhance the machine effectiveness. This regulator works when the FLC1 stops searching the generator speed. It helps in reducing the iron loss by reducing the rotor flux.



By doing this the overall efficiency increases. Against Turbines oscillations third fuzzy controller is used which works all the time. This regulator compares the change in the wind speed occurs due to wind vortex.

By the use of the fuzzy system performance of the wind farm has been increased.

The fuzzy rules utilized as a part of the framework are widespread and can be implemented for numerous systems.

Fuzzy system helps in predicting human problems and model imprecise information.

XII. REFERENCES

- [1] OECD and IEA, "World Energy Outlook 2011," *Http://Www.Iea.Org*, p. 577, 2011.
- [2] S. Choudhury, "Performance Analysis of Doubly-fed Induction Generator in Wind Energy Conversion System Performance Analysis of Doubly-fed Induction Generator in Wind Energy Conversion System," no. 209, 2011.
- [3] F. L. Controller, "Fuzzy Logic Based Speed Control System for Three- Phase Induction Motor," no. 1, pp. 17–28, 2013.
- [4] E. Muljadi and B. Parsons, "Comparing Single and Multiple Turbine Representations in a Wind Farm Simulation Preprint," *Contract*, no. March, 2006.
- [5] B. K. Bose, "Fuzzy logic and neural networks in power electronics and drives," *IEEE Ind. Appl. Mag.*, vol. 6, no. 3, pp. 57–63, 2000.
- [6] E. Adzic, Z. Ivanovic, M. Adzic, and V. Katic, "Maximum power search in wind turbine based on fuzzy logic control," *Acta Polytech. Hungarica*, vol. 6, no. 1, pp. 131–149, 2009.
- [7] H. M. Farh and A. M. Eltamaly, "Fuzzy logic control of wind energy conversion system," *J. Renew. Sustain. Energy*, vol. 5, no. 2, pp. 935–940, 2013.