



SINGLE PHASE SPWM BASED INVERTER FOR PHOTOVOLTAIC SYSTEM WITH MAXIMUM POWER POINT TRACKING

Prachi Agarwal¹ and Girish Parmar²

^{1,2}Department of Electronics Engineering, Rajasthan Technical University, Kota, (India)

ABSTRACT

Inverter is basically an interface between DC source like photovoltaic cell and AC networks. There are many inverter topologies but output current distortion and efficiency are the two main parameters for the selection of inverters. This paper proposes a single-phase inverter for photovoltaic systems. The system consists of a switch mode DC-DC boost converter and H-bridge inverter. Furthermore, the intelligent PV module system is implemented using a simple maximum power point tracking (MPPT) method. Here, the SPWM (Sinusoidal Pulse Width Modulation) technique of unipolar inverters is presented and simulated in MATLAB. The SPWM pulses are generated by comparison of two waves- a carrier wave, which is triangular in this case and a modulating reference wave whose frequency is the desired frequency, and is sinusoidal in this case.

Keywords: *Maximum Power Point Tracking (MPPT), Photovoltaic (PV) System, And DC-DC Converter, PWM, Unipolar Inverter, LC Filter.*

I. INTRODUCTION

The characteristic voltage and power of a photovoltaic (PV) array is nonlinear and time varying due to the changes caused by the atmospheric conditions, therefore a maximum power point tracking algorithm is adopted to maximize the output power [1-3]. P&O based PV system has been used as the input source for the proposed inverter topology [4-5]. The major issue lies in converting the available DC sources into AC sources. Therefore, we proposed a two-stage intelligent PV system, which is similar to modular configuration topology. In an intelligent PV module instead of interconnection between modules they are interconnected with associated DC-DC converter for MPPT tracking which ensures optimal operations of PV module. Various MPPT algorithms exist in different literatures. In this paper, we propose perturb and observe (P&O) method to extract maximum possible power from solar panel. Here, a two-stage PV system is proposed which consists of a DC-DC boost converter with MPPT and a DC-AC inverter to convert photovoltaic DC voltage into line 50 Hz AC voltage as shown in Fig. 1. In order to minimize the switching losses and to achieve better performance of the inverter, a combination of SPWM and a triangular wave signal is used for switching the inverter circuit [6-7]. The work has been carried out/simulated in MATLAB/SIMULINK environment.

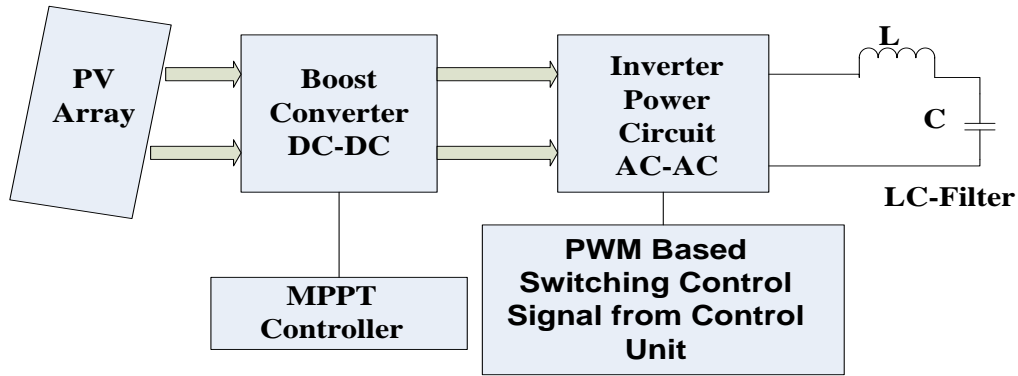

Fig.1. Block diagram of two-stage filter connected PV system

II. MATHEMATICAL MODELLING OF PV CELL

The equivalent electrical circuit of an ideal PV cell can be treated as a current source parallel with a diode, as shown in fig.2.

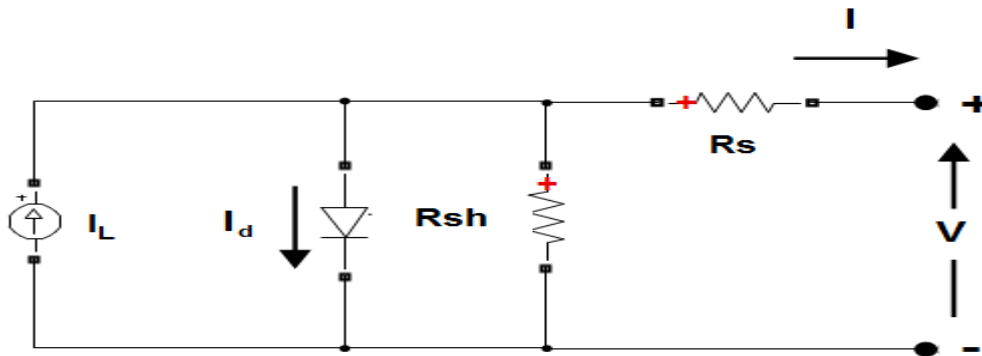

Fig.2. Equivalent electrical circuit of a solar cell

The basic equation from the theory of semiconductor which mathematically describes the I-V characteristics of the ideal PV cell is [8]:

$$I = I_{pv,cell} - I_d \tag{1}$$

where,

$$I = I_{pv,cell} - I_{0,cell} \left[\exp\left(\frac{qV}{\alpha kT}\right) - 1 \right] \tag{2}$$

$$I = I_{pv} - I_0 \left[\exp\left(\frac{V + R_s I}{V_t \alpha}\right) - 1 \right] - \left(\frac{V + R_s I}{R_p} \right) \tag{3}$$

where,

$I_{pv,cell}$: Current generated by the incident light, I_d : The Shockley diode equation

$I_{0,cell}$: The reverse saturation current of the diode, q : Electron charge ($1.60217646 \times 10^{-19} \text{C}$)

k : Boltzmann constant ($1.3806503 \times 10^{-23}$), T : Cell Temperature in Kelvin (k)

V : Solar cell output voltage (V), R_s : Solar cell series resistance (Ω)

R_p : Solar cell parallel resistance (Ω).

The cells which are connected in parallel will increase the current whereas the cells connected in series provide improved output voltage.

III. PERTURBATION AND OBSERVATION ALGORITHM

P&O algorithm reads the values of voltage and current from solar PV module to evaluate maximum power to be tracked. The value of voltage and power at k^{th} instant is stored in the memory. Then next value at $(k+1)^{th}$ instant is measured again and power is compared with the previous measured values. The power and voltage at $(k+1)^{th}$ instant is subtracted with the values from k^{th} instant [9].

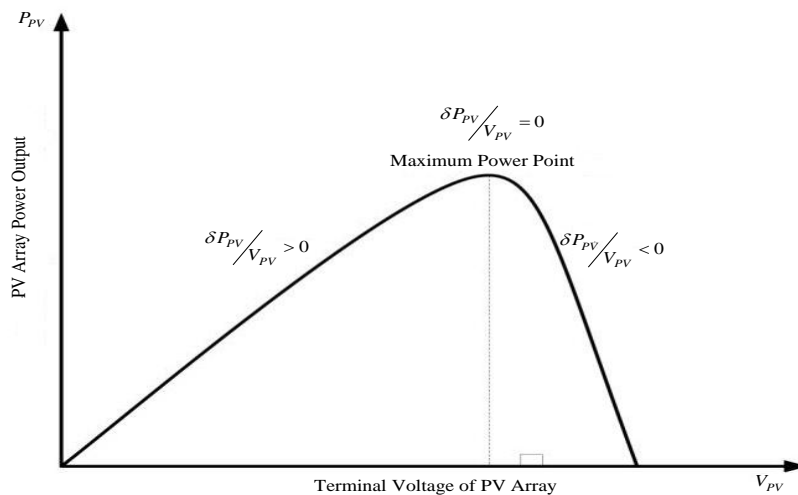

Fig.3. P-V Characteristics of photovoltaic cell

From fig. 3, it is observed that right hand side of the curve where the voltage is almost constant the slope of $\frac{\delta P}{\delta V} < 0$ is negative whereas in the left hand side, the slope $\frac{\delta P}{\delta V} > 0$ is positive. The right side of the curve is nearer to zero (lower duty cycle) whereas the left side of the curve is nearer to unity (higher duty cycle). Depending on the sign of $\delta P_{pv}(P_{pv} - P_{pv}(k+1))$ and $\delta V_{pv}(V_{pv} - V_{pv}(k+1))$ after subtraction the algorithm decides whether to increase the duty cycle or to reduce the duty cycle. The MPPT algorithm has been implemented at dc-dc boost converter side. The logic has been elaborated according to the flow chart of P&O algorithm, shown in fig. 4 [9,18]. The duty cycle lies in between 0 and 1. According to the change in the power δP_{pv} and the change in the voltage δV_{pv} , the duty cycle of the converter is changed as given in the following logic [12],

If $\delta P_{pv} > 0$ and $\delta V_{pv} > 0$ then $\alpha = \alpha - \delta\alpha$

If $\delta P_{pv} > 0$ and $\delta V_{pv} < 0$ then $\alpha = \alpha + \delta\alpha$

If $\delta P_{pv} < 0$ and $\delta V_{pv} < 0$ then $\alpha = \alpha + \delta\alpha$

If $\delta P_{pv} < 0$ and $\delta V_{pv} > 0$ then $\alpha = \alpha - \delta\alpha$

where α = duty cycle and $\delta\alpha$ is perturbation.

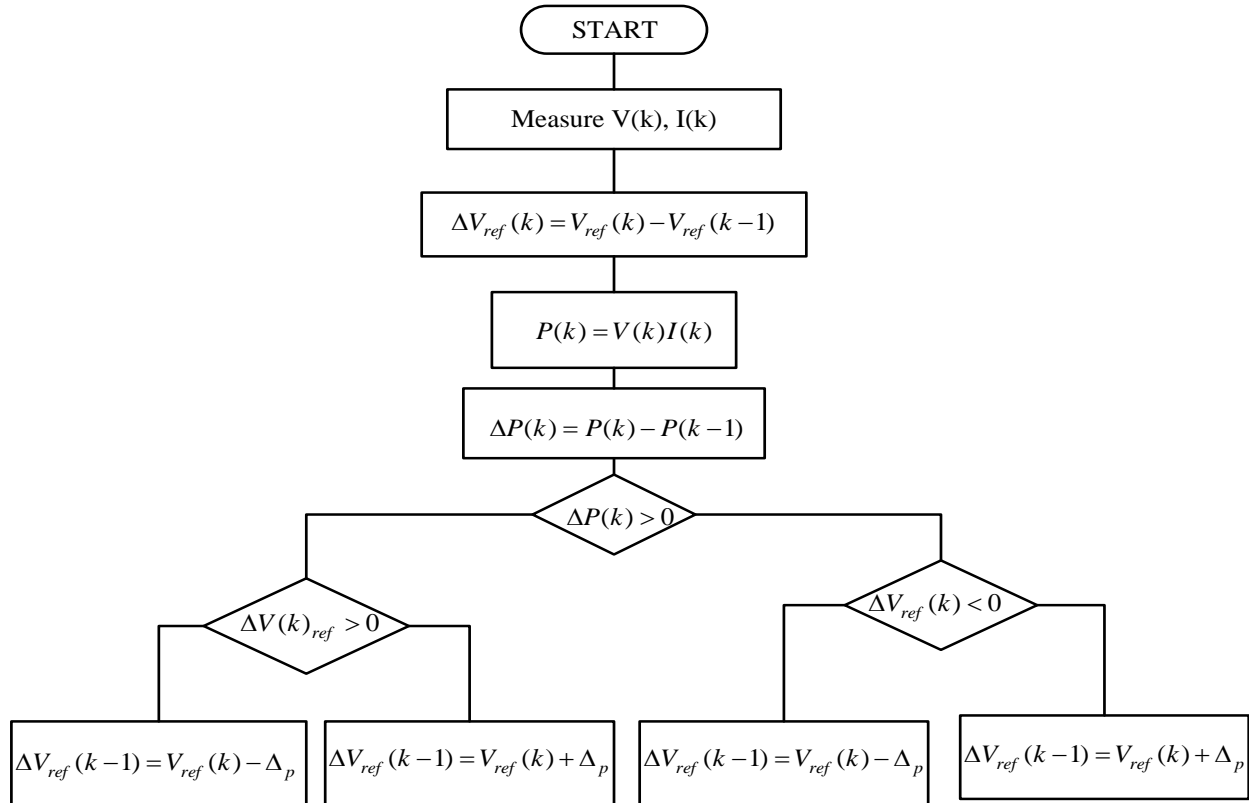

Fig.4. Flow chart of Perturb and Observe algorithm for MPPT

V. DC-DC BOOST CONVERTER

A boost converter is a step-up DC-DC power converter, which converts a low input voltage to a high output voltage. In this situation, the output current is lower than source current. Converter operation can be divided into two modes; first mode begins, when the transistor is switched on, the current increases linearly in the boost inductor, and when the diode is in off state, mode second begins, when the transistor is switched off, the energy stored in the inductor is discharged through the diode to the source load [10-11]. The classical relationship between input and output voltage of a boost converter at steady state condition is given by:

$$\frac{V_0}{V_i} = \frac{1}{1-D} \tag{4}$$

where, duty cycle D lies between 0 and 1 [12].

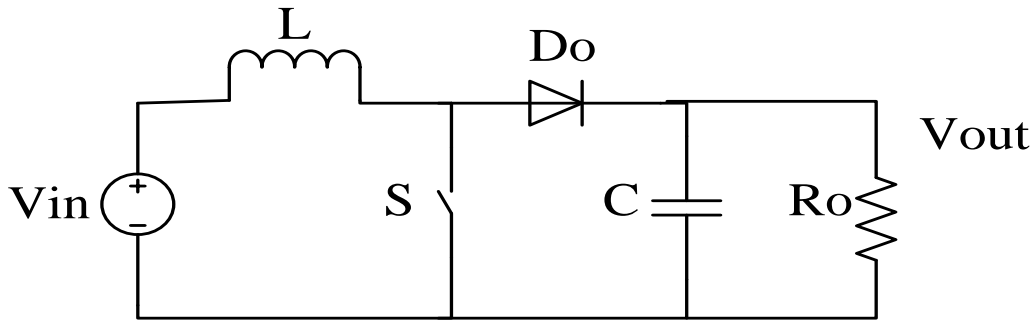

Fig.5. Boost Converter Circuit

VI. SINGLE PHASE SPWM INVERTER CIRCUIT

In SPWM (Sinusoidal Pulse Width Modulation) two signals are compared. The Modulating reference signal is sinusoidal and the carrier wave is triangular [6]. Gating pulses are produce by comparing the two signals and the width of each pulse is varied is proportion to the amplitude of the sine wave. The frequency of the reference signal determines the inverter output frequency and the reference peak amplitude controls the modulation index and the RMS value of the output voltage. The unipolar modulation normally requires two sinusoidal modulating waves v_m and v_{m-} which are of same magnitude and frequency but 180° out of phase. The two modulating wave are compared with a common triangular carrier wave v_{cr} generating two gating signals m_a and v_{g3} for the upper two switches S1 and S3. It can be observed that the upper two devices do not switch simultaneously, which is distinguished from the bipolar PWM where all the four devices are switched at the same time. The inverter output voltage switches between either between zero and $+V_d$ during positive half cycle or between zero and $-V_d$ during negative half cycle of the fundamental frequency thus this scheme is called unipolar modulation. The unipolar switched inverter offers reduced switching losses and generates less EMI [7]. On efficiency grounds, it appears that the unipolar switched inverter has an advantage. Over modulation occurs when amplitude modulation index m_a is greater than unity. It causes a reduction in number of pulses in the line to line voltage waveform leading to emergence of lower order harmonics. Moreover the notch and pulse widths near the center of positive and negative half cycle tend to vanish. To complete the switching operations of the device, minimum notch and pulse widths must be maintained. When minimum width notches and pulses are dropped, there will be some transient jump of load current

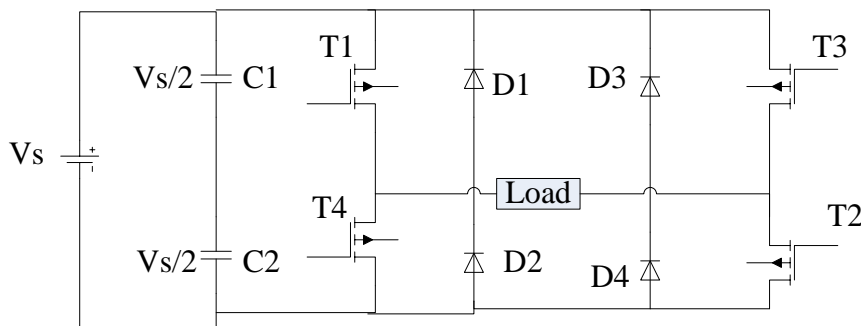

Fig.6. Single Phase Full Wave Bridge Inverter

Table.1 Switching States

| T1 | T2 | T3 | T4 | Va | Vb | Vab |
|-----|-----|-----|-----|------------------|------------------|--------|
| ON | OFF | OFF | ON | $\frac{V_s}{2}$ | $-\frac{V_s}{2}$ | $-V_s$ |
| OFF | ON | ON | OFF | $\frac{V_s}{2}$ | $\frac{V_s}{2}$ | $-V_s$ |
| ON | OFF | ON | OFF | $\frac{V_s}{2}$ | $-\frac{V_s}{2}$ | 0 |
| OFF | ON | OFF | ON | $-\frac{V_s}{2}$ | $\frac{V_s}{2}$ | 0 |

Output voltage from an inverter can also be adjusted by exercising a control within the inverter itself. The most efficient method of the same is pulse width modulation control used within an inverter

VII. SIMULATION RESULTS AND DISCUSSIONS

The simulated PVA model is shown in fig. 7. This model has fixed temperature and irradiance; temperature of cell is 25⁰ C & irradiance is 400 W/m².

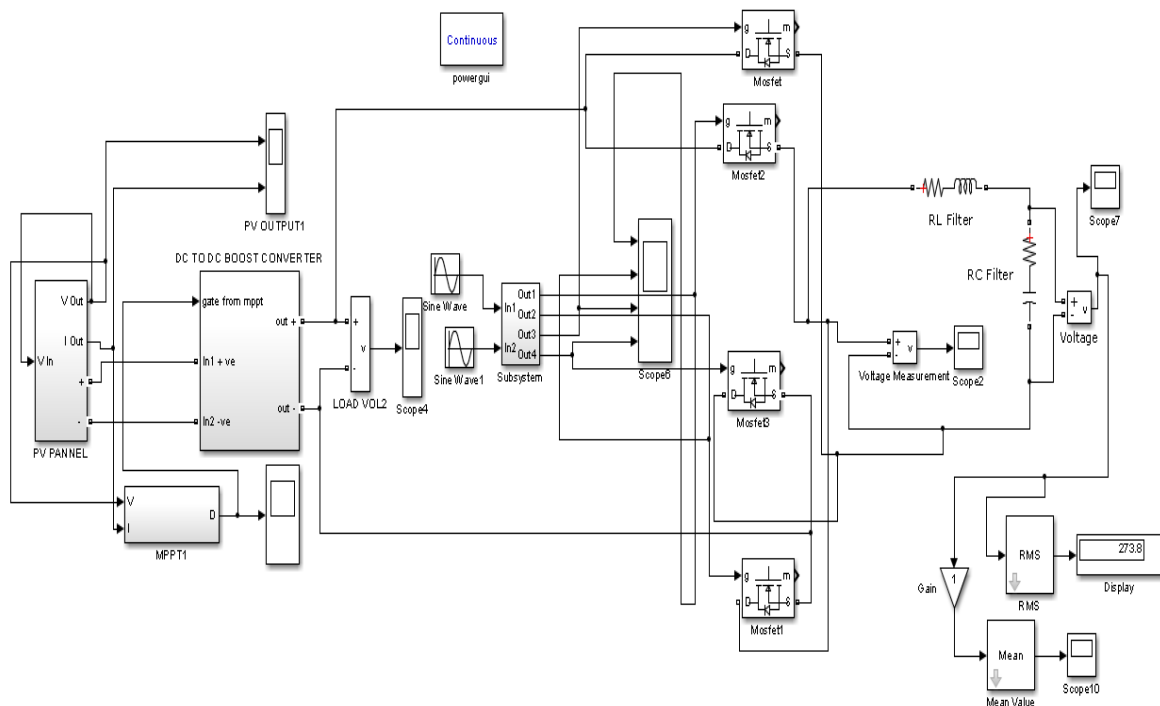

Fig.7. Complete Simulink Diagram of PVA system

The output of PV panel is connected with the boost converter. The output voltage of boost converter are shown in figs .8

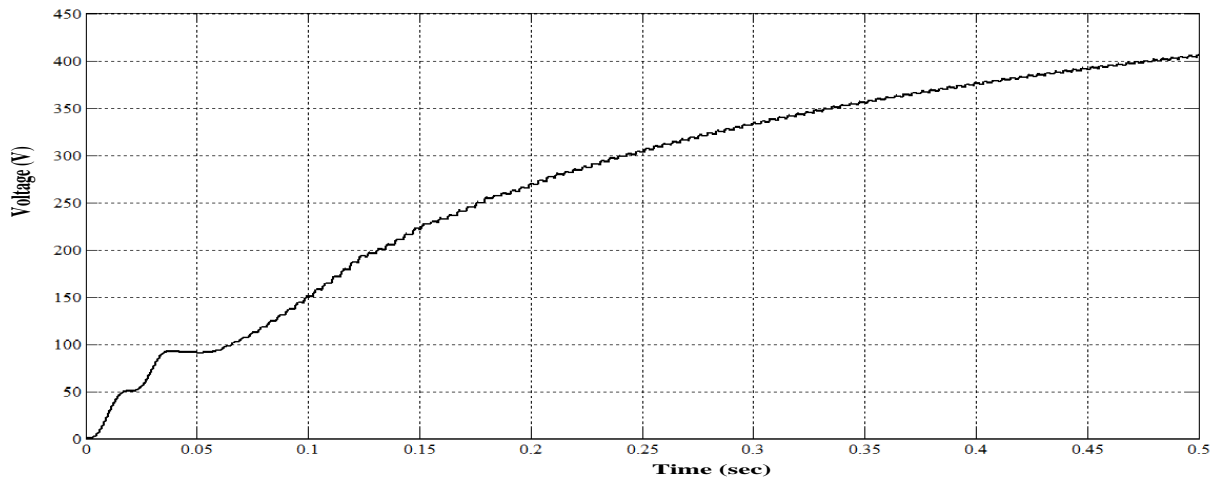

Fig.8. Boost converter output voltage with P&O algorithm

Fig.9 to fig.12 shows the obtained simulation results of reference and carrier waveform applied to the PWM for providing gating pulse to inverter

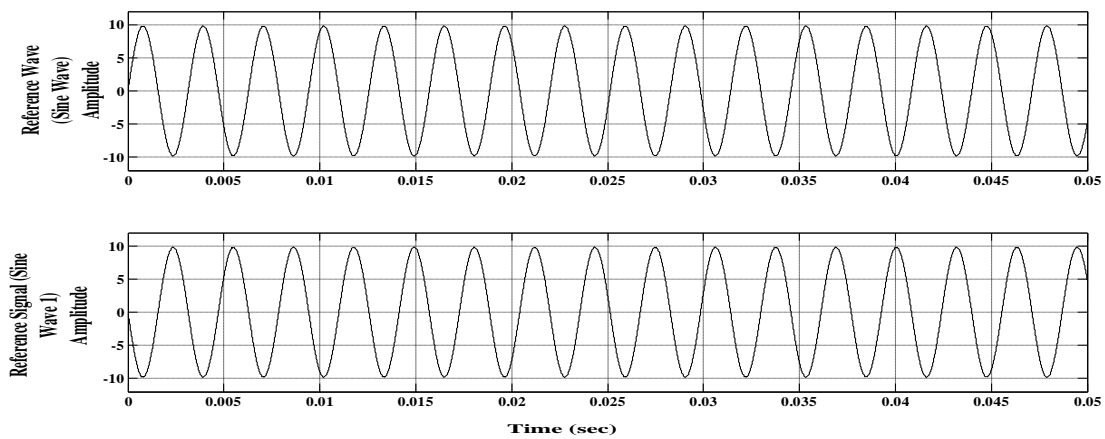

Fig.9. Waveform of Reference Wave for SPWM with unipolar voltage switching

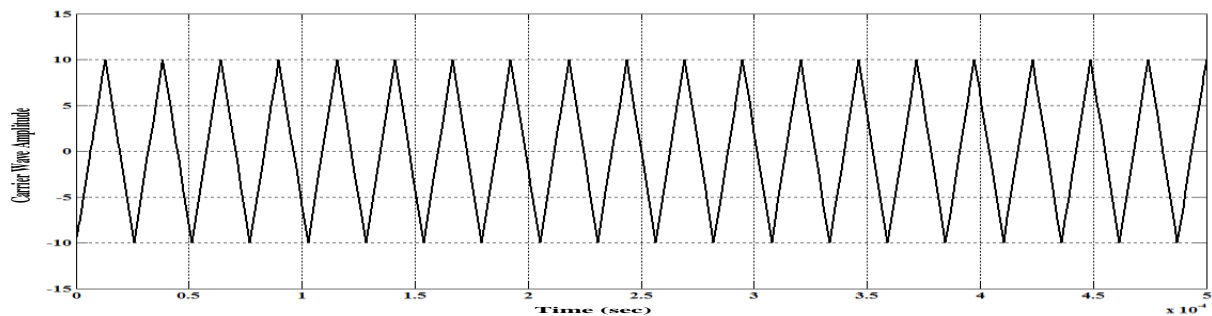

Fig.10. Waveform of Carrier Wave for SPWM with unipolar voltage switching

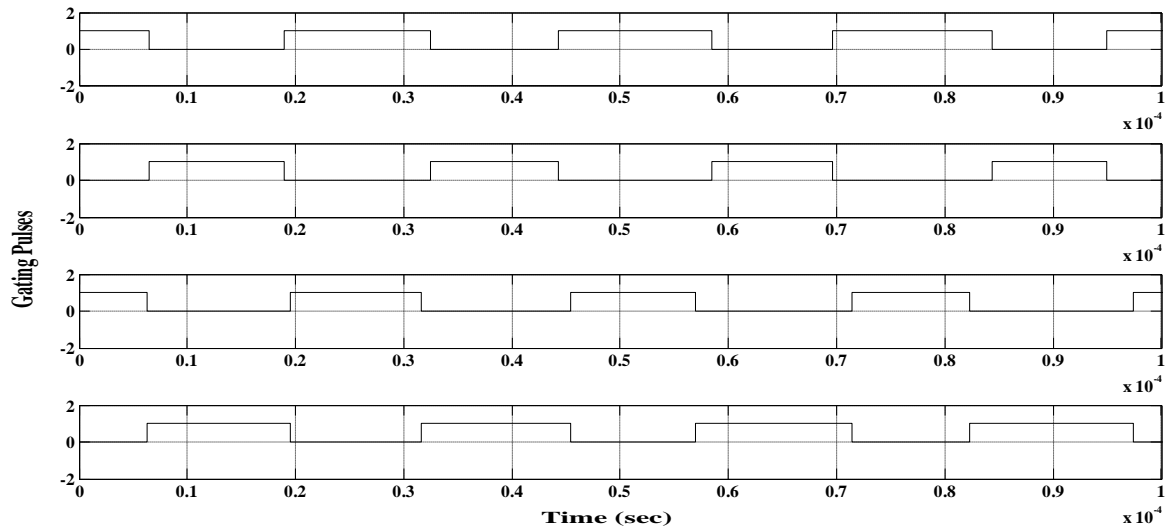

Fig.11. Switching Signal from Control Circuit for MOSFET T1, T2, T3, T4

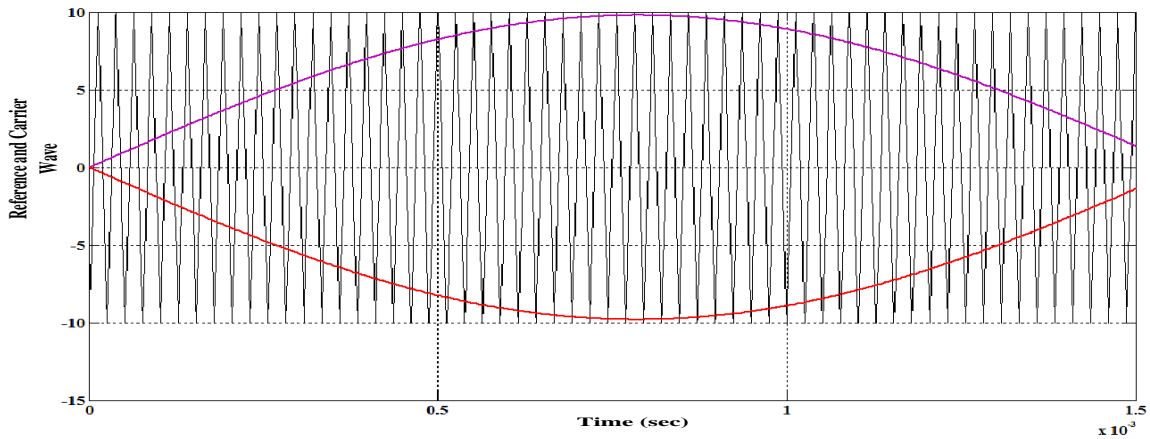

Fig.12. Waveform of Reference and Carrier Wave for SPWM with unipolar voltage switching

The output of boost converter is then fed to the inverter which converts DC to AC. The output from inverter is fed to the LC filter. The output voltage of the inverter is shown in fig. 13-14.

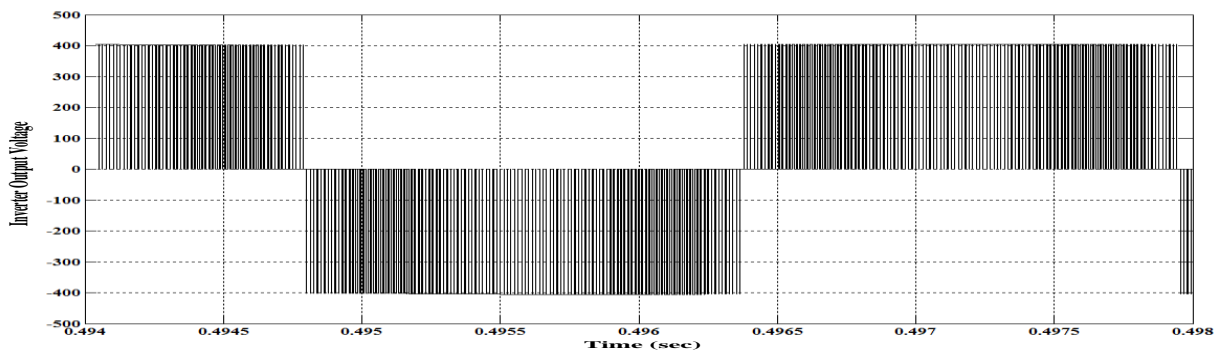

Fig.13. Output Voltage of the Inverter

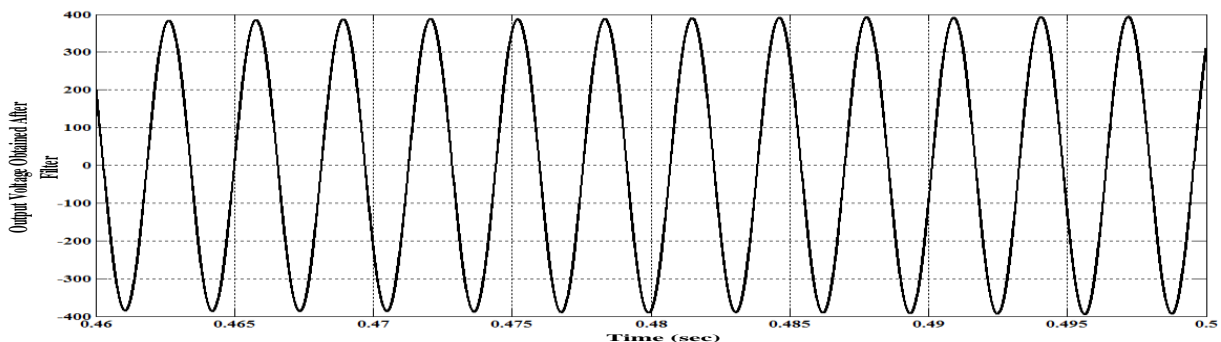

Fig.14. Output voltage waveform of Unipolar Voltage Switching with filter

VIII. CONCLUSIONS

The objective of this paper is to establish a model for the photovoltaic system with maximum power point tracking. A single phase two-stage photovoltaic inverter with combination of SPWM and triangular-wave switching strategy has been designed in MATLAB. In the proposed design, an MPPT algorithm with a boost converter is designed to operate using (P&O) method to control the PWM signals of the boost converter, which is adapted to the maximum power tracking in PV system. Instead of using line frequency transformer at the inverter output terminals, a DC-DC boost converter is used between solar panel and inverter that efficiently amplify the 80 V PV arrays output into 400 V DC, which is then transformed into line frequency (50Hz) sinusoidal ac 280V rms voltage by the inverter and thereby reducing the system losses and ensuring high voltage gain and efficiency. The simulation results show that the proposed photovoltaic inverter trace the maximum power of solar module and then converts it to a high quality ripple free sinusoidal ac power.

REFERENCES

- [1] J. Rodriguez and J. Lai. J, "Multilevel inverters: a survey topologies, control and applications", *IEEE Trans. Ind. Electron.* 49, vol. 4, No.724-738, Aug. 2002.
- [2] A.H Mohd Nordin, A.M Omar and Hedzlin Zainuddin, "Modeling and simulation of grid Inverter in grid connected photovoltaic system", *International Journal of Renewable Energy Research*, vol. 4, No. 4, 2014.
- [3] Jayalakshmi N. S, D. N. Gaonkar, Anusree Balan, Prasanna Patil and Syed Adil Raza, "Dynamic modeling and performance study of a stand-alone photovoltaic system with battery supplying dynamic load", *International Journal of Renewable Energy Research*, vol.4, No.3, 2014
- [4] Mida Dris and Benattous Djilani, "Comparative study of algorithms (mppt) applied to photovoltaic systems", *International Journal of Renewable Energy Research*, vol.3, No.4, 2013.
- [5] K. L. Lian, J. H. Jhang and I. S. TianA, "Maximum power point tracking method based on perturb-and-observe combined with particle swarm optimization" *IEEE Journal of Photovoltaics*, vol. 4, No. 2, March 2014..
- [6] Pankaj H Zope, Pravin G.Bhangale, Prashant Sonare ,S. R.Suralkar "Design and Implementation of carrier based Sinusoidal PWM Inverter", *International Journal of Advanced Research in Electrical, Electronics and Instrumentation Engineering*, vol. 1, Issue 4, October 2012, ISSN: 2278 - 8875.



- [7] Hongrae Kim ,Babak Parkhideh, Tim D. Bongers and Heng Gao ,“Reconfigurable Solar Converter: A Single-Stage Power Conversion PV Battery System”, *IEEE TRANSACTIONS ON POWER ELECTRONICS*, vol. 28, NO. 8, August 2013.
- [8] Mukesh Kumar, Dr S.R.Kapoor & Rajkumar Nagar,” Comparison between IC and Fuzzy Logic MPPT Algorithm Based Solar PV System using Boost Converter”, *International Journal of Advanced Research in Electrical, Electronics and Instrumentation Engineering*, vol. 4, Issue 6, June 2015.
- [9] N. Femia, G. Petrone, Giovanni Spagnuolo and M. Vitelli, “Optimization of Perturb and Observe Maximum Power Point Tracking Method”, *IEEE Transactions on Power Electronics*, vol.20, no.4, 2005, pp.963-973.
- [10] Mohammed A. Elgendy, Bashar Zahawi & David J. Atkinson, “Assessment of the Incremental Conductance Maximum Power Point Tracking Algorithm” *IEEE Transactions On Sustainable Energy*, vol.4, No.1, Jan.2013.
- [11] Snehamoy Dhar, R Sridhar and Geraldine Mathew, “Implementation of PV Cell Based Standalone Solar Power System Employing Incremental Conductance MPPT Algorithm” *IEEE International Conference on Circuits, Power and Computing Technologies (ICCPCT)*, pp.356-361, 2013.
- [12] H.E.A. Ibrahim and Mahmoud Ibrahim, “Comparison Between Fuzzy and P&O Control for MPPT for Photovoltaic System Using Boost Converter” *Journal of Energy Technologies and Policy*, vol.2, No.6, pp.1-11, 2012.
- [13] P. Akash Pattanaik, Naresh K Pilli and S K Singh, “Design, Simulation & Performance Evaluation of three phase grid connected PV panel”, *2015 IEEE Power, Communication and Information Technology Conference (PCITC) Siksha ‘O’ Anusandhan University, Bhubaneswar, India*.
- [14] Pratheesh. K.J, Jagadanand.G and Rijil Ramchand, “An Improved Space Vector PWM Method for a Three-Level Inverter with Reduced THD”, *Compatibility and Power Electronics (CPE), 2015 9th International Conference*.
- [15] A. K. Sharma, T. D. Saxena, S. Islam and Arun Kumar Yadav, “Performance Analysis of Three Phase PWM Voltage Source Inverter Fed Three Phase Induction Motor Drive”, *International Journal of Advanced Electrical and Electronics Engineering (IJAEED)*, vol. 2, pp.45 – 52, 2013.
- [16] Neeraj. M. K, L. Sanjeev Kumar and Shri Harsha J, “Three Phase Voltage Source Inverter for Front End Rectifier Fed to Ac-Motor Drive Using Matlab”, *International Journal of Engineering Science and Innovative Technology (IJESIT)* vol. 4, Issue 3, May 2015.
- [17] Jatin A. Patel and Hardik H. Raval, ”Design of Three Phase Sinusoidal Pulse Width Modulation Inverter”, *International Journal of Advance Research in Engineering, Science & Technology (IJAREST)*, vol. 2, Issue 7, July- 2015.
- [18] Prachi Agarwal and Girish Parmar,”Perturb and Observe Based PV System with PWM Inverter and Its THD Analysis” *International Conference on Recent Development in Engineering Science, Humanities and Management (ESHM-2017)*, January 29, 2017 NITTTR, Chandigarh, India.