



## WIRELESS PATIENT MONITORING SYSTEM USING ZIGBEE

Prasad Kulkarni<sup>1</sup>, Aniket Shinde<sup>2</sup>, Sushil Sonawane<sup>3</sup>,  
Mahesh Shiroadkar<sup>4</sup>, Akash Khade<sup>5</sup>

<sup>1</sup>Assistant Professor, Electrical Engineering Dept, SETI, Panhala, Maharashtra, (India)

<sup>2,3,4,5</sup> Student, Electrical Engineering Dept, SETI, Panhala, Maharashtra, (India)

### ABSTRACT

This study paper includes a design of Arduino based system for wireless patient's health parameters which consists of Heart beat, O<sub>2</sub> level, Glucose level and Temperature. Now a days many human beings in India suffers from diseases like heart attack, diabetes, cancer and reason behind that, they are not getting proper and timely monitoring in hospitals. Also this system will give indication for taking medicine and diet in proper time to the patient. This problem generally occurs in multispecialty hospitals where numbers of patients are in diagnosis process. Soin this paper we developed system which transmit the data from patient to doctor's PC.

**Keywords :** ECG (Electro Cardio Gram), LCD (Liquid Crystal Display), ADC (analogue to digital converter), LDR (Light Dependent Resistor).

### I INTRODUCTION

Wireless patient monitoring system became vital in day to day life because of fast growing diseases in human life and this reflects in rapidly increasing demands in hospitals. This whole system measure the physical parameter of the patient's body and this real time data transmit to the central PC, which is kept at doctors cabin. Recently there are two methods in practice that is wireless ECG monitoring and alarm system using ZigBee and other is heartbeat monitoring alert via SMS. This paper includes physical parameter monitoring sensor circuits with ZigBee module as transmitter at bed and as receiver at central PC. To ensure the successful transmission of all health parameters, there is visual basic software used on central PC.

### II SYSTEM REPRESENTATION

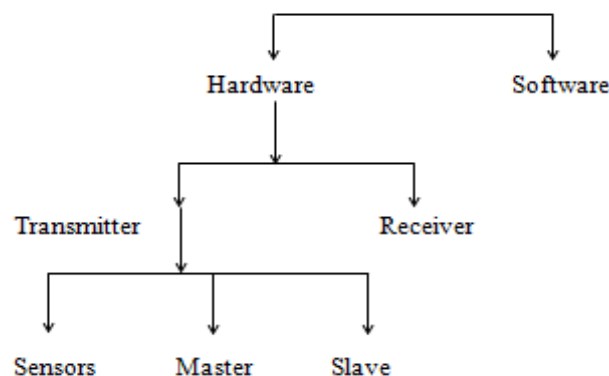

Overall system consist of mainly two parts i.e. hardware and software. Whereas hardware part consist of two sections i.e. transmitter and receiver, in which transmitter developed by four sensors, Master and Slave type combination. In master circuit four input sensors viz. O<sub>2</sub> level, temperature, heartbeat and saline level are connected to the controller ATmega328. This controller will give the output on the LCD and also on doctor's PC via Zigbee transmitter, whereas there is a Zigbee receiver model at doctor's PC. Range of this Zigbee module is 100mtrs.

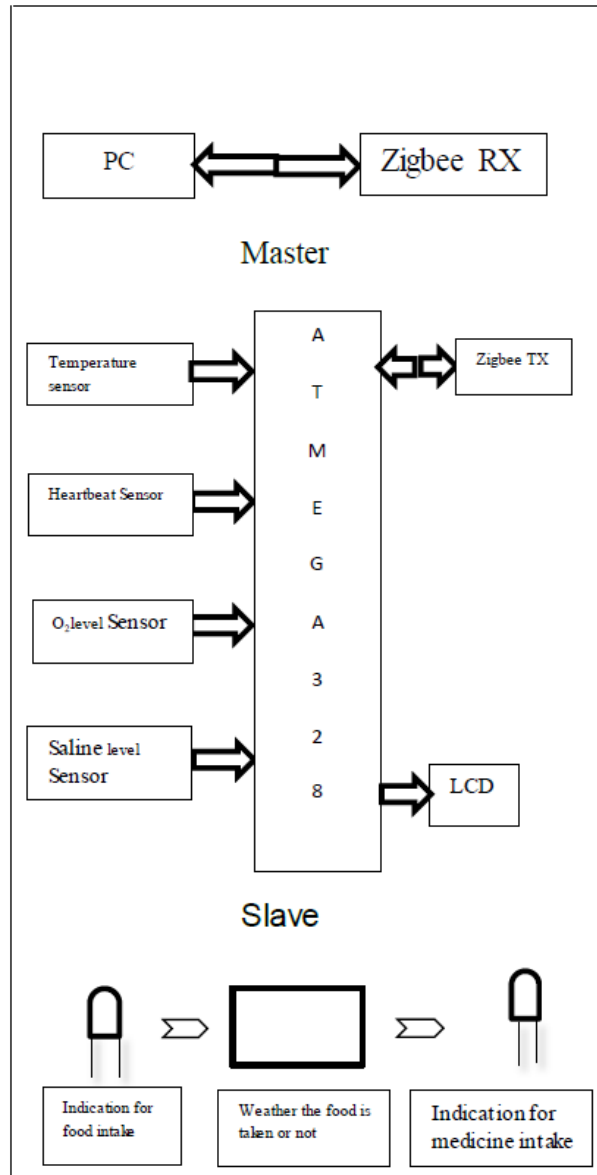

Fig- Main Block Diagram

The status of all the slaves is checked by the master circuit. System gives continuous data which is coming from four input sensors to doctor. The transmission signal is shown on both master and slave circuit. In the request frame the master shows the slave ID. The request frame is received by the slave, which are in range and stored to the RAM memory. If the incoming slave ID matches with their own slave ID then they accept the frame and send the parameter back to the master. When slave goes out of range then the communication fails. The slave

should be placed in such way that they will be always in range of the PC master. The slave is under the PC based masters supervision. Therefore the PC master will communicate to the slave via Wireless Zigbee module. Apart from this main circuit there is another facility is provided to the patient gives the indication for food intake at respective meal timing. After half an hour of food intake weight of patient is checked on special weighing machine connected to the bed. If weight of patient get increased by at least just 200gm then signal is send to microcontroller and this gives output of food taken message to doctor's pc. After this message patient get message for medicine intake on LCD which is connected to the bed.

### III COMPONENT DESCRIPTION

#### 3.1 Controller (ATMEGA328)

Controller is heart of our system. This controller following features: 32Kbytes of in-system programmable flash with read-while-write capabilities, two 8-bit Timer/Counters, 23 programmable I/O Lines, and operating Voltage is 1.8 - 5.5V, Temperature Range -40°C to 105°C, three flexible Timer/Counters. Pin configuration of ATmega328 IC consists of 28 pins. There is Port B, Port C & Port D an 8-bit bi-directional I/O port with internal pull-up resistors.

#### 3.2 Input Sensors

##### 3.2.1 IR Sensor

The pulse rate sensor is basically used to keep track on the pulse rate of the person. In programming the maximum and the minimum set point are provided for the pulse rate. If the pulse rate goes below or above the set point then the alert will be immediately issued by the m Sensor is the essential part of any instrumentation system. Sensing is the first stage of any process in the instrumentation system. Sensors are required to sense the variations in the physical quantities. According to the variations in the physical quantities sensors give the output, which is electrical in nature.



**Fig- Heartbeat Sensor**

### 3.2.2 Temperature Sensor

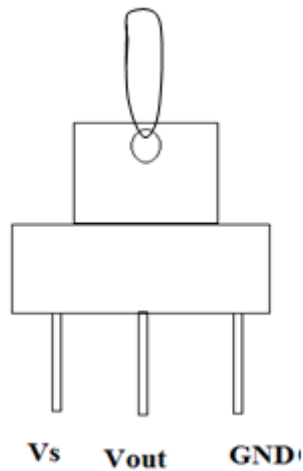
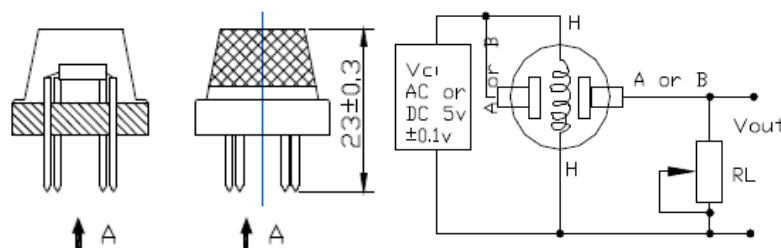

**Fig- Temperature Sensor**

Temperature sensor senses the temperature of body. It can sense the temperature of human body. It is an analog sensor and gives the output into form of analog signal. This signal is feed to ARM controller and ADC will convert it into digital form. Once converted into analog form the controller can process the digital temperature signal as per the application.

### 3.2.3 Oxygen Sensor

Structure and configuration of MQ-6 gas sensor is shown as Fig. 1 (Configuration A or B), sensor composed by micro AL<sub>2</sub>O<sub>3</sub> ceramic tube, Tin Dioxide (SnO<sub>2</sub>) sensitive layer, measuring electrode and heater are fixed into a crust made by plastic and stainless steel net. The heater provides necessary work conditions for work of sensitive components. The enveloped MQ-6 has 6 pin, 4 of them are used to fetch signals, and other 2 are used for providing heating current



**Fig- Oxygen Sensor**

### 3.2.4 Saline Level Sensor

For this sensor rather than using liquid level sensor LDR and LED is used to detect the level of liquid in saline bottle. For this sensor LED act as a transmitter and LDR acts as receiver. When Liquid is present in between the transmitter and receiver light is cannot pass through the liquid so it gives result in present otherwise it gives absent result so we get status of liquid in bottle.

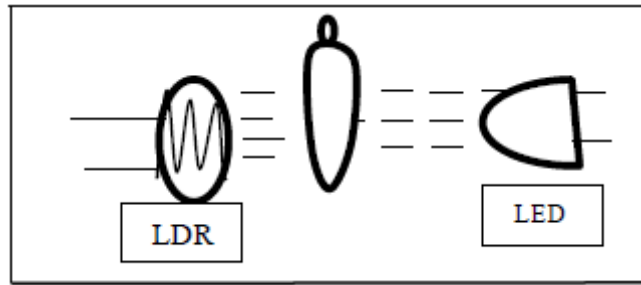

Fig- Saline Level Sensor

### 3.2.5 Weighing Sensor

Weighing sensor i.e. load cell of approximate 300kg are used for weigh the patient's body. For weigh the body four load cells are used at each leg of bed. After this output of all load cell is connected to the motherboard for conversion from resistance to voltage and this is used for further process.



Fig- Load Cell

### 3.3 LCD

The 16/2 LCD display is used to visualize the output of the application. It issued to check the output of different modules interfaced with the microcontroller. Thus LCD plays a vital role to see the output and to debug the system module wise in case of system failure in order to rectify the problem display device is required only at the coordinator end. To know what is going on the sensing node. The data must be shown on the display. This data can also be recorded and kept safe for the analysis. Health status of the human can only be known by observing the data. That's why the display is must for the presented application. For the presented work, LCD is used as a display device. LCD is the short form of the liquid crystal display. LCD displays utilize two sheets of polarizing material with a liquid crystal.

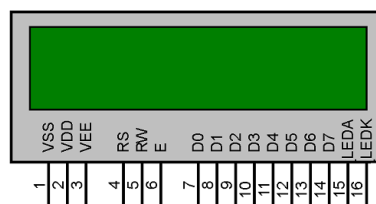

Fig- LCD Display

### 3.4 Power Supply

There are several components used at the sensing node and coordinator end. These components have different operating voltage such as controller operates at 3.3 – 5v. ZigBee transceiver operates at 1.8 V to 3.8 V, LM 35 and LCD display operates at 5 V. To meet these requirements of different operating voltage ranges a proper

arrangement of power supply is required. The 7805 voltage regular is used to provide 5 V regulated power supply.

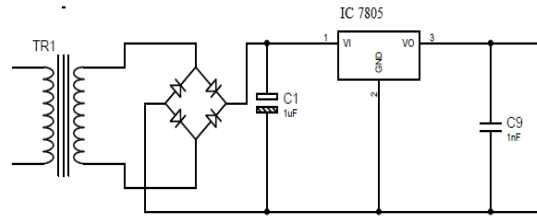

Fig- Power supply

## IV RESULTS

### ❖ Output on Doctor's PC

### Output on Bedside LCD 1

```
sushil - HyperTerminal
File Edit View Call Transfer Help
[Icons]
HR=74 T=31 H=24
02=Pre. Glu=AbsHR=68 T=31 H=26
02=Pre. Glu=AbsHR=70 T=31 H=26
02=Pre. Glu=Abs T=31 H=26
02=Pre. Glu=AbsHR=72 T=31 H=26
02=Abs. Glu=AbsHR=71 T=31 H=26
02=Abs. Glu=AbsHR=69 T=31 H=26
```



### ❖ Output on Bedside LCD 2

### Output of weighing machine at bed

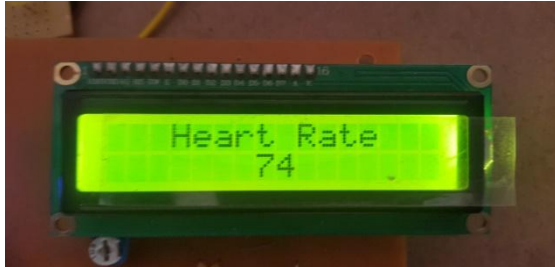

## V FUTURE SCOPE

1. In future work of our system we can connect number of beds to this system by using ARM64.
2. Also we can give the message of medicine intake to respective relative of patient.
3. ECG monetization is also possible by using this system.

## VI CONCLUSION

This designed system gives accurate result of human body parameters; also system gives indication of food and medicine intake it also checks whether the food is taken or not. System is more flexible to handle.

## REFERENCES

- [1] Rubina. A. Sheikh "Real time health monitoring system of remote patient using ARM7" International Journal of Instrumentation, Control and Automation (IJICA) ISSN: 2231-1890, Vol-1 Iss-3, 4, 2012.



- [2] 2011 International Conference on Information and Network Technology IACSIT Press, Singapore  
“Remote Patient Monitoring- An Implementation in ICU Ward”, Arun, Marimuthu, Pradeep, Karthikeyan.
- [3] AmrutaChopade, Prof. Nitin Rout, “Remote Patient’s Health Monitoring by Using Zigbee Protocol”,  
International Journal of Advanced Research in Computer Science and Software Engineering Volume  
4, Issue 8, August 2014, ISSN: 2277128x.