



AUTOMATIC BIKE STAND

Shubham Bagul¹, Nikhil Dhake², Deepak Mengal³, Padmakar Jadhav⁴, Ms.

Divya R. Dhagate⁵, Prof. Sunil M. More⁶

*^{1,2,3,4}Third Year Electrical Students, ^{5,6} Assistant Professor, Department of Electrical Engineering,
Guru Gobind Singh Polytechnic Nashik, Maharashtra, India*

ABSTRACT

A two wheeler refers to vehicles that run on two wheels. They include, bicycle, a pedal-powered two wheeler. Motorcycle is the motor-powered two wheeler, similar in construction with bicycles.

But also considering that the parking of vehicles in parking places is necessity. So that stand must be used at the parking.

Considering this area the automation of stand is taken into account for our project. This automation is very useful at the parking the vehicle.

This automation is related to the limit switch. The system uses the two limit switch which is placed two places of stand. When the limit switch is actuated the stand will automatically placed.

If another limit switch is actuated the side stand will automatically returns to the initial position. When limit switch is actuated the signal is passed to the micro controller from the limit switch. The micro controller saves the data and actuates the relay.

This relay is used to actuate the motor. Thus by the stand is placed. If another limit switch is operated this sends the signal to the micro controller. So this actuates the relay thus the motor is operated and the stand is return to the initial position.

This automation is very useful at the time of parking. This is the simplest method and can be suitable for all automobile two wheeler vehicle.

Keywords: PIC (usually pronounced as "pick") is a family of microcontrollers

I. WORKING

Automatic side-stand retrieve system retrieves the side-stand automatically, if the rider forgets to lift the side-stand while moving the bike. It works based on the working principal of the two-wheelers. Every bike transmits power from engine's pinions to the rear-wheels. (i.e.: Rotary motion of the pinion makes the linear motion of the chain) That linear motion of the chain is observed by rear wheel's sprocket and converted rotary motion. The rotary motion of the rear wheel makes the bikes to move. "Based on this sprocket side stand retrieve system is designed. The sliding set-up and inciter assembly are engaged position in vehicle rest condition. The side stand is connected to the sliding set-up by using the clutch cable. In running condition the inciter assembly rotates and strikes the sliding set-up. So the sliding set-up pulls the side stand by using clutch cable. The side stand retrieved

automatically. The sliding set-up and inciter assembly are de-engaged position in vehicle running condition. so the vehicle is move without power loss.

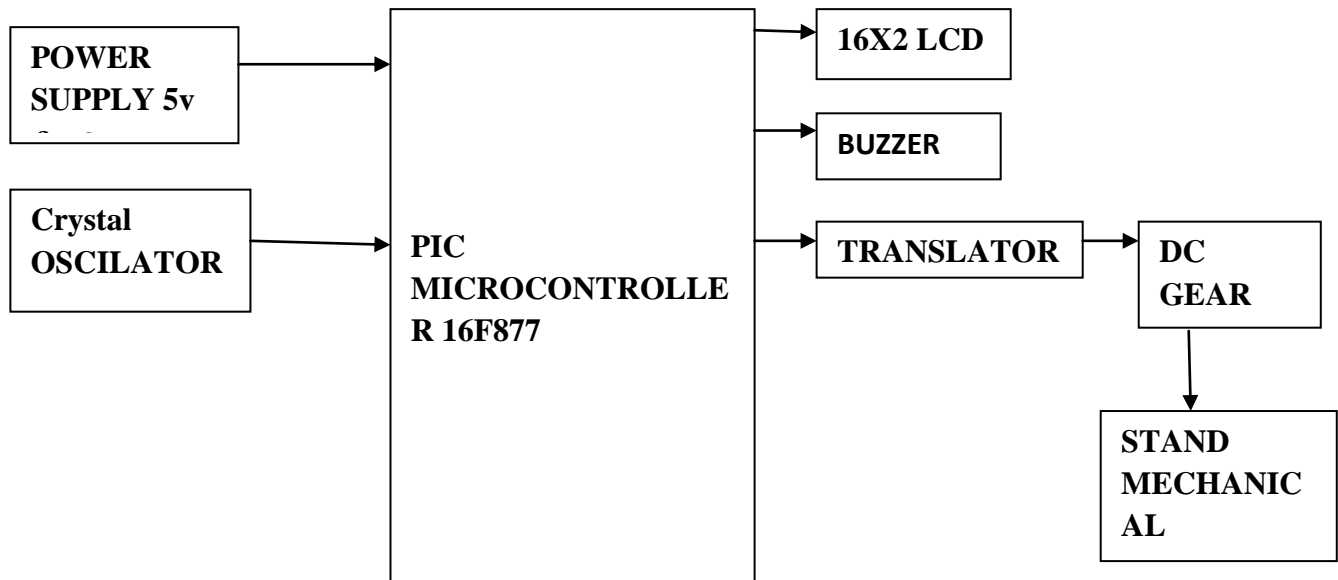

Figure :-Block Diagram Of The System

❖ PIC MICROCONTROLLER

The Controller is heart of entire system, whole system should be analyzed in selecting proper controller. Microchip manufacture a series of microcontroller called PIC. There are many different flavors available, some basic low memory type, going right up through to one that have Analog-To-Digital converters and even PWM built in.

❖ POWER SUPPLY

We required 5 volts for microcontroller, sensor, LCD. Primary function of power supply is to convert one form of electrical energy to another. All electronic circuits use DC power supply of adequate voltage for their operation.

❖ LCD DISPLAY

In this project LCD is used to display some message which is useful to motorcycle driver. Here, 16x2 LCD (Liquid Crystal Display) is used. This is used to display message like,

II. BIKE STAND AUTOMATION

- STAND UP

- STAND DOWN

❖ SWITCH BUTTON :-

In Electrical Engineering, a switch is an electrical component that break an electrical circuit, interrupting the current or diverting it from one conductor to another.

❖ DC GEAR MOTOR :-

It converts direct current electrical power into mechanical power. The speed of motor is counted in term of rotation of the shaft per minute and is termed as RPM. Dc motor is designed for two speed operation. It consist of



three brushes namely common, low speed, high speed. Two of the brushes will be supplied for different mode of operation. The DC motor does not oscillate back and forth, it rotates continuously in one direction like most other motors. The rotational motor is converted to the back and forth wiper motion by a series of mechanical linkage. This type of motor is called a gear head or motor ends has advantage of having lots of torque. The DC motor works on 12volt DC battery.

❖ **SIDE STAND :-**

It is a device on a Motorcycle that allows the bike to be kept upright without leaning against another object or the aid of a person. A stand is usually a piece of metal that flips down from the frame and makes contact with the ground. It is generally located in the middle of the bike or towards the rear.

III. ADVANTAGES

1. It's cost wise less than other method.
2. This method does not affect the engine efficiency.
3. It's does not affect the structure of a vehicle.
4. It's easily fitted in the vehicle than other method.
5. It's a weight less method.
6. Electrical supply not required.

IV. APPLICATIONS

1. This method reduces the side stand accidents in two wheelers. This method also used for with gear and without gear of two wheelers.
2. In bikes.

Example :Active, Unicorn, Royal Enfield.

➤ **ShubhamBagul :-**

I am Member of our Group. I got 60% in 1st year & 62 % in 2nd year.

➤ **Nikhil Dhake :-**

I am Member of our Group. I got 56% in 1st year & 58% in 2nd year.

➤ **Deepak Mengal :-**

I am Member of our Group. I got 60% in 1st year & 60 % in 2nd year.

➤ **PadmakarJadhav :-**

I am Member of our Group. I got 58% in 1st year & 60% in 2nd year

V. CONCLUSION

In this project, a novel method of automatic bike stand is been designed and developed for motorcycle bike drivers. As everyone in today's world is riding bike it is essential to take care of unwanted troubles. Each and every bike should have automatic bike stand.



VI. FUTURE SCOPE

This project can be modify by using speed sensor. The KMI 15/X and KMI 16/X are magneto resistive sensor modules with an integrated signal conditioning electronics to provide a simple and cost effective solution for rotational speed measurement .Due to their compact design-in and therefore time to market dis-significantly reduced. theKMI sensor modules consist of the magneto resistive sensor element, a permanent magnet fixed to his sensor and the integrated signal conditioning circuit designed in bipolar technology.

REFERENCES

- [1.] www.google.com
- [2.] www.wikipedia.com