



CONTAINER VEHICLE SAFETY SYSTEM BY USING GEAR POSITION AND GSM MODULE

Snehal Kumbhar¹, Vijay Pawar², Vaibhav Saste³

SVPM's COE, Malegaon (BK) Baramti, Pune

ABSTRACT

Currently almost of the people having an own vehicle, theft is happening on parking and sometimes driving insecurity places. The safe of vehicles is extremely essential for public vehicles. Vehicle security and accident prevention is more challenging. So, in order to bring solution for this problem this system can be implemented. Vehicle security enhancement and accident prevention system can be developed through the application of ignition control, fuel theft, accident detection and prevention, driver fatigue and speed limiting with efficient vehicle management system. The need for this project is to provide security to the vehicles by engine locking system which prevents the vehicle from unauthorized access. This technique helps to find out the exact location of the accident and with the help of server an emergency vehicle can be sent to the exact location to reduce the human life loss. It also detects the behavior of the driver through sensors whether he is drowsy or drunk, so that occurrence of accident can be prevented. The place of vehicle identified using Global system mobile communication (GSM). This is more secured, reliable and low cost.

Keywords: LCD, BUZZER, GSM MODULE, ULTRA SONIC SENSOR.

I. INTRODUCTION

In the last few decades, India has progressed at such an enormous rate that many companies have strongly established themselves here. These companies bring a huge amount of workforce with them. The development of satellite communication technology is easy to identify the vehicle location, vehicle tracking system have brought this technology to the day-to-day life of the common person. Today GPS used in car, ambulances, police vehicles are common sights on the roads of developed countries. All the existing technology support tracking the vehicle place and status.

The GSM/GPS Based System is one of the most important systems, which integrate both GSM and GPS technologies. It is necessary due to the many of applications of both GSM and GPS systems and the wide usage of them by millions of people throughout the world. This system designed for users in land construction and transport business provides real-time information such as location, speed and expected arrival time of the user is moving vehicles in a concise and easy-to-read format. This system may also useful for communication process among the two points robbed vehicle to parallel the stolen vehicle engine speed going to decreased and pushed to off. After switch off the engine motor cannot restart without permission of password. This system installed for the four wheelers. Vehicle tracking usually used in navy operators for navy management functions, routing, send-off, on board information and security. The applications include monitoring driving performance of a parent with a teen driver. Vehicle tracking systems accepted in consumer

vehicle as a theft prevention and retrieval device. If the theft identified, the system sends the SMS to the vehicle owner. After that vehicle owner sends the SMS to the controller, issue the necessary signals to stop the motor.

II. RELATED WORKS

We decided to work on design and development of container vehicle safety system project. For the information we search on internet and some reference books also.

When we search on internet we found some IEEE Research papers as follows:

Prof. A. Rajkiran, M. Anusha published paper, "Intelligent Automatic Vehicle Accident Detection System Using Wireless Communication". They used LPC2148 ARM. GPS and GSM technique is used to track location of vehicle.

Pooja Kothale, Prof. S. M. Kulkarni published paper". Arm 7 Embedded Controllers for Vehicle Obstacle detection and Safety System". It is mainly concentrated on obstacle detection. It detects obstacle at some defined distance from the vehicle to avoid accidents.

M. Abinaya, R. Uthira Devi , "Intelligent Vehicle Control Using Wireless Embedded System Based On GSM and GPS Technology". They used PIC 16F887 microcontroller. This system is used to track vehicle and to detect drivers status, whether he is drowsy or not.

III. BLOCK DIAGRAM:

The block diagram of this proposed research work "Container Vehicle Safety System" has power (12V), ARM7, LCD, sensors like fire sensor, ultrasonic sensor, alcohol sensor, gear position sensor, speed sensor and GSM module. ARM7 is core of this system which controls all operations and energized with 3.3V power. ARM7 is used because of better features like: it is low power, high performance 32-bit RISC processor (32-bit data & address bus) microcontroller, Fully static operation ideal for power-sensitive applications

32 I/O lines, low power idle and power-down mode

Power supply is given to microcontroller and peripherals. Peripheral such as 16x2 LCD, BUZZER, LED are connected to microcontroller. Sensors such as speed sensor, fire sensor, ultrasonic sensor, gear position sensor, alcohol sensor are connected to microcontroller. GSM is connected via MAX 232..

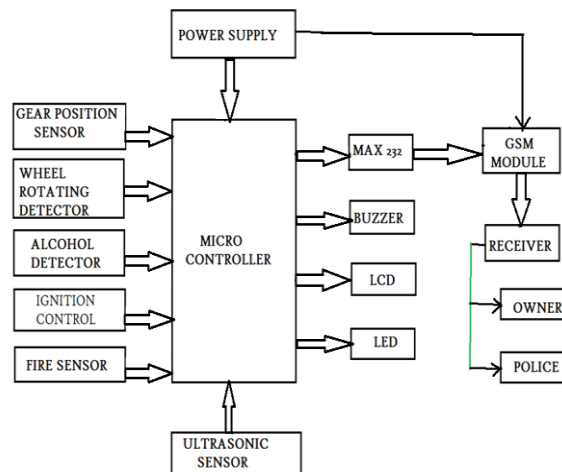



IV. ADVANTAGES:

1. Avoid accidents.
2. Watch on driver is possible via remote places.
3. Implemented in less cost and easy working

V. APPLICATIONS

1. Used in container vehicle.
2. Automotive application.
3. Public transport system.
4. Modern cabs, cars, auto rikshaw.

VI. CONCLUSION

The complete safety of container vehicle is done, now we can keep an eye on vehicle and can provide help easily if needed. Also the accidents are avoided successfully.

REFERENCES

- [1.] Saif Ai-sultan, Ali H. Ai-Bayatti and Hussien Zedan ,”Context Aware Driver Behavior Detection System in Intelligent Transportation System”.
- [2.] S. Sonica, Dr. K. Sathiyasekar, S. Jaishree, ”Intelligent Accident Identification System Using GSM Modem”.
- [3.] V. Ramya, B. Palaniappan, K. arthick, ”Embedded Controller for vehicle In-Front Obstacle Detection And Cabin Safety Alert System”.