



AUTOMATIC PHASE SELECTOR USING MICRO-CONTROLLER AT89C51

**Mr. Prasad Salunkhe¹, Digvijay Raut²,
Madhuri Patil³, Poonam salunkhe⁴, Mohd Yusuf⁵**

^{1,2,3,4} Under Graduate Student , Dept. of Electrical Engineering,
YSPM'YTC College, Maharashtra, (India)

⁵ Assistant Professor , Dept of Electrical Engineering,
YSPM'YTC College, Maharashtra, (India)

ABSTRACT

Phase absence is a very common and severe problem in any industry, home or office. Many times one or two phases may not be live in three phase supply. Because of this, many times, some electrical appliances will be on in one room and OFF in another room. This creates a big disturbance to our routine work. This project is designed to check the availability of any live phase, and the load will be connected to the particular live phase only. Even a single phase is available, and then also, the load will be in ON condition. This project is designed with ATME89c51 MCU. This controller continuously checks for live condition of all phases connected to it, and the controller connects the load to the active phase using a Relay. This relay is driven with a transistor. If two or three phases are live, the load will be connected to Phase 1 only. An LCD is provided to display the status of the phase condition. Contrast control preset is given for LCD contrast control. This project uses regulated 12V, 500mA power supply. 7805 three terminal voltage regulator is used for voltage regulation. Bridge type full wave rectifier is used to rectify the ac output of secondary of 230/12V step down transformer.

Key Words: ATME89c51, ADC, B, PCB, R, Y

I INRODUCTION

Power instability in developing countries creates a need for automation of electrical power generation or alternative sources of power to back up the utility supply. This automation is required as the rate of power outage becomes predominantly high. Most industrial and commercial processes are dependent on power supply and if the processes of change-over are manual, serious time is not only wasted but also creates device or machine damage from human error during the change-over connections, which could bring massive losses.

A manual change-over switch consists of a manual change-over switch box, switch gear box and cut-out fuse or the connector fuse as described by Rocks and Mazur (1993). This change-over switch box separate the source between the generator and public supply, when there is power supply outage from public supply, someone has to go and change the line to generator. Thus when power supply is restored, someone has to put OFF the generator and then change the source line from generator to public supply. In view of the above manual change-over switch system that involves manpower by using ones energy in starting the generator and switching over from public supply to generator and vice-versa when the supply is restored.

The importance attached to cases of operation in hospitals and air ports in order to save life from generator as fast as possible makes it important for the design and construction of an automatic change-over switch which would solve the problem of manpower and the danger likely to be encountered changeover. The electronic control monitors the incoming public supply voltage and detects when the voltage drops below a level that electrical or electronic gadgets can function depending on the utility.

II LITERATURE SURVEY

In three-phase applications, if low voltage is available in any one or two phases, and you want your equipment to work on normal voltage, this circuit will solve your problem[1]. The automatic phase changer was made from electronic components which includes; operational amplifiers, diodes, resistors, capacitors, Zener diodes, transformers, relays and fuses. Results obtained during the test shows that, whenever the system senses a higher voltage across the three inputs and then engages the load [2]. There are many designs and prototype systems that can perform almost similar functions like, single phase change-over switches, two phase automatic transfer switch and three phase automatic change-over switch, but this prototype is about an automatic phase switchover (phase selector) which is designed for only three phase A.C input power to single phase output applications[3]. The system is high complexity in “Automatic Voltage Regulator “ using ac voltage – voltage convertor developed by Steven .M Hietpas [4]. As statistical analysis were complicated to achieve in single detection Automatic Phase Shift Method for finding Detection of Grid Connected Photo Voltaic inverter [5]. The system is basically designed to select between the three phases at reasonable speed, and also address phase imbalances with respect to loads. In other words, the switching consideration demonstrates the real and practical situation for mainly domestic, moderate industrial advanced needs [3].

III BLOCK DIAGRAM

There are three phases R, Y, B which are given to signal conditioning block as shown in fig. below. The sensors signal which is then pass to the microcontroller 89c51 which is interface with LCD. A relay driver circuitry as shown in the fig is mainly the electrically operated switch. The main purpose behind using such a relay circuitry is the complete electrical isolation between input and output, and to control the low power signal. The output of this system is in the form of an electric bulb which glows for the correct output voltage.

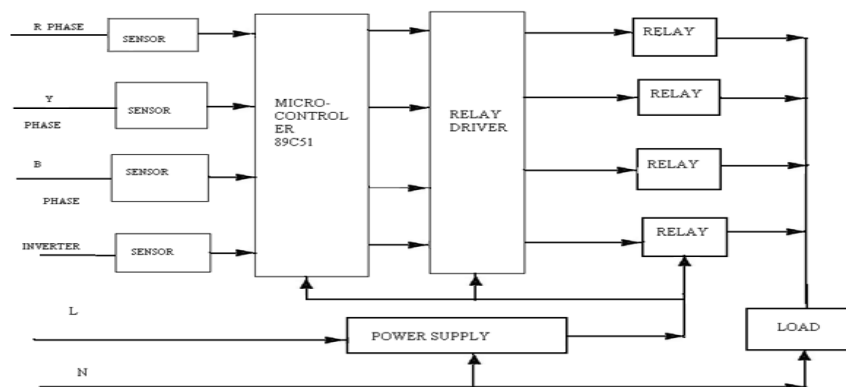

Fig. 3.1 Block Diagram of Automatic Phase Changer

IV LOGIC ANALYSIS

The truth table expression may contain any number of lines (any number of inputs may be at logic "1"), but only one output will be at logic "1". This means that only a particular phase has the highest priority and must be carried out first. "X" in the truth table indicates the, absent of input, i.e. the input may be at logic 0 or 1.

Table No. 4.1 Truth Table

Truth table								
Logic Input				Control logic Output				Final Output
R	Y	B	INV	R	Y	B	INV	
1	X	X	X	1	0	0	0	R PHASE
0	1	X	X	0	1	0	0	Y PHASE
0	0	1	X	0	0	1	0	B PHASE
0	0	0	1	0	0	0	1	INV PHASE

V WORKING PRINCIPLE



In three-phase applications, if low voltage is available in any one or two phases, and you want your equipment to work on normal voltage, this circuit will solve your problem. However, a proper-rating fuse needs to be used in the input lines (R, Y and B) of each phase. The circuit provides correct voltage in the same power supply lines through relays from the other phase where correct voltage is available. Using it you can operate all your equipment even when correct voltage is available on a single phase in the building. The circuit is built around a transformer, comparator, transistor and relay. Three identical sets of this circuit, one each for three phases, are used.

The operation starts with converting the 230v, 50Hz AC supply to 12v, 50Hz i.e. step downing the main supply as per the need of the system by using transformer of EE20 / 4 - 0.08VA.[6] Then rectifiers are used to convert AC to DC which are fully rectified to get pulsating DC but to filter this pulsating signal from the diode. A filter capacitor is used to pure DC. Which is given further to the voltage regulator & is also provided to 12v relay which works on DC supply? Regulator LX78MXX [7]converts 12v to 5v which is given to microcontroller, ADC & LCD display. The AT89C51 is a low-power, high-performance CMOS 8-bit microcomputer with 4K

bytes of Flash programmable and erasable read only memory (PEROM).[8]. The device is manufactured high-density non volatile memory technology and is compatible with the industry-standard MCS-51 instruction set and pin out. The on-chip Flash allows the program memory to be reprogrammed in-system or by a conventional non volatile memory programmer. By combining a versatile 8-bit CPU with Flash on a monolithic chip, the AT89C51 is a powerful microcomputer which provides a highly-flexible and cost-effective solution to many embedded control applications.[8]. Then a power LED above ADC is used to indicate power supply ON/OFF to the circuitry along with a register. 4, 12v DC, 30ma current relay along with relay drive circuitry used. Which comprises a LED for indication of relay ON/OFF & 400k ohm resistors are serially attached for LED to limit the current.

Then 4 pull-up resistors are used to increase the current of circuitry. Then the output of ADC is given to microcontroller & then microcontroller decides whether which phase is off & it is display on LED. A 16*2 alpha numeric LED is used i.e. 16 character & alphabetical value & numerical value along with 100ohm resistor which is a current limiting resistor to control the back light. Input pulses are used for manual operation which has a manual switch, R switch, Y switch, B switch and inverter (I) switch to select the phase.

VI OUTPUTS



Using four step-down transformer to step down the AC signal which is rectified filtered & then to decrease the voltage so a pot is used which acts as a voltage divider which is given to ADC so that the voltage limit should be 0 to 5v. On auto mode R-phase is present and after turning the phase OFF it automatically shifts to Y- phase & indications are shown on LED across the block relay across microcontroller. After turning OFF Y- phase & it automatically shifts to B-phase after turning OFF Y-phase. There are four buttons out of which the first you can select R, Y, B, I any of the four in manual phase switchover. A bulb is used as a load to indicate phase change at the output.

VII ADVANTAGE

- Highly sensitive
- Works according to the phase availability
- Fit and Forget system



- Low cost and reliable circuit
- Complete elimination of manpower
- Can handle heavy loads up to 7A

VIII APPLICATIONS

Residential, Commercial offices, Factories operating with 1 phase machineries, Hospitals/Banks, Institutions. It automatically supplies voltage in case of power failure or low voltage in up to 2 of the 3 incoming phases. Automatic Phase Changer automatically cuts supply during low voltage thus, protects equipment from the harmful affects of unhealthy low voltage.

IX CONCLUSION

The circuit provides correct voltage in the same power supply lines through relays from the other phase where correct voltage is available. Using it you can operate all your equipment even when correct voltage is available on a single phase in the building. Hence using this project we can reduce problem related with sudden power interruption.

REFERENCES

- [1] Muhammad Ajmal P. "Electronics For You" July 2007
- [2] Muhammad Ajmal P. (2007), *Automatic Phase Changer*. Retrieved: 11/02/2014.
- [3] Oduobuk E. J.& Ekpenyong, E. E. "Design and Implementation of Automatic Three Phase Changer Using LM324 Quad Integrated Circuit" *International Journal of Engineering and Technology Research Vol. 2, No. 4*, April 2014.
- [4] Steven M. Hietpas, Mark Naden, "Automatic Voltage regulator using an AC Voltage-Voltage Converter" *IEEE Transaction on Industrial Application, Vol 36, no 1*, January-February 2000.
- [5] Gua-Kiang Hung, Chih- chang Chang, "Automatic Phase Shift Method for Islanding Detection of Grid – Connected Photovoltaic Inverters" *IEEE Transaction On Energy conversion, Vol.18.No.1*, March 2003.
- [6] 12060 TRANSFORMER – DATASHEET
- [7] LX78MXX VOLTAGE REGULATOR – DATASHEET.
- [8] ATMEL89C51- MICROCONTROLLER DATASHEET