



REVIEW PAPER ON “ENERGY CONSERVATION AND GENERATION BY VEHICLE-TO-GRID (V2G) IN SMART PARKING”

**Pritesh Bhila Ahire¹, Pratik Kusan Bedase²,
ShubhamBhujang Tangade³, Pankaj Ramesh Shelke⁴**

^{1,2,3,4}Electrical Department, Sandip Polytechnic, Sandip Foundation, Nashik, Maharashtra, (India)

ABSTRACT

In present scenario the fossil fuels are diminishing day by day and the demand of the power is more than the supply. By 2050, the fossil fuels will diminish. Major consumer of fossil fuel is vehicle. In conventional vehicles energy conservation is difficult. To conserve energy, modern automobile technology is moving toward electric vehicle but electrical vehicle have a major drawback of availability of charging station. This drawback can be overcome by an advanced parking scheme employee's vehicle to grid connection. In advanced parking scheme when an electric car is parked, energy may be withdrawn from grid or supplied to grid depending upon requirement of car battery. The one of the way to conserve and provide energy to grid by advanced parking scheme by Vehicle-to-grid (V2G). Vehicle-to-Grid (V2G) presents a mechanism to meet key requirements of the electric power system, using electric vehicles when they are parked and underutilized. So in parking smart wired/ wireless charging and discharging battery of the vehicle with two way communications available between the vehicle and the grid and renewable resources such as wind, solar and piezo. In addition with light sensors are employed to conserve energy. This generated and conserved energy will be provided to grid.

Keywords: *Vehicle-To-Grid(V2G), Renewable Energy Sources, Motion Sensors*

I INTRODUCTION

In present scenario the fossil fuels are diminishing day by day and the demand of the power is more than the supply. By 2050, the fossil fuels will diminish.

In smart parking system by using different methods to reduce the consumption of fossil fuel and electrical energy.

In smart parking generation of electricity is possible by using renewable sources (solar, wind, piezo [4,2] and vehicle to grid (V2G) [1]. Smart parking system supports to grid to fulfill the requirement of energy in peak hours [3].

II METHODS AND MATERIAL

In smart parking system conservation and generation of energy can be done by various methods as they are following

2.1 Vehicle to grid

In parking system when electric vehicle is park in the parking, since there is no use of electric vehicle batteries use for the electricity flow from the battery to the grid [1].

In smart parking twoway communications is possiblebetween vehicle to grid and grid to vehicle

2.1.1 How Vehicle To Grid Is Work?

The power generated from various sources such as renewable sources and conventional energy sources and this power distributed through grid. This power can be used to charge electric vehicle in smart parking system [1].

The battery of electric vehicle is utilized to fulfill the energy requirement during peak hours [3]

2.1.2 How to fulfill the energy requirement during peak hours?

In vehicle to grid system electric vehicle can be used as a storage device. This stored power can be utilized to feed electric grid during peak hours [3].

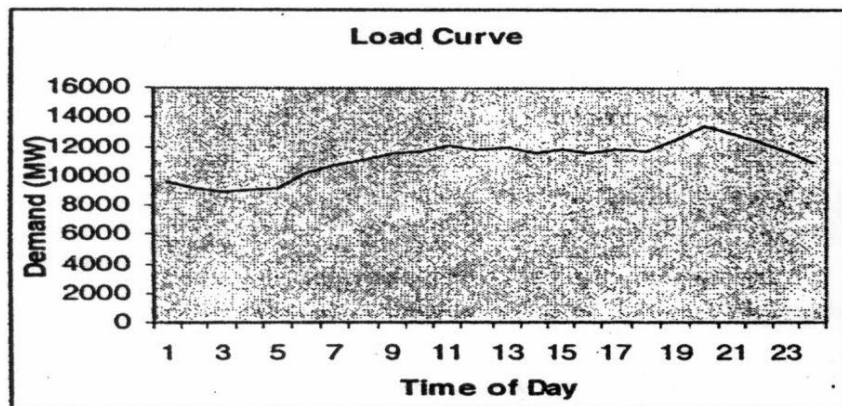

Fig.(1) Load curve (Time of day tariff)

TOD Tariff (In addition to Base Tariff):

Consumption during following hours of the day	Energy Charge (p/u)
2200 hrs - 0600 hrs	-85
0600 hrs - 0900 hrs	0
0900 hrs - 1200 hrs	80
1200 hrs - 1800 hrs	0
1800 hrs - 2200 hrs	110

Fig.(2) Time of day tariff energy charges per unit

For example, in industrial sector from above graph during time 1-5 energy demand(MW) is less and energy charges for per unit is also less at this time battery of vehicle is charged at low cost.

And during time 18-22 in peakhour's batteries energy is fed to the grid to support to grid

2.2 Renewable Energy Sources

2.2.1 Solar

Solar energy most reliable, cleanest and easy to available form of renewable form of energy. Solar powered photovoltaic (PV) panels to convert solar energy into electric energy [4].

In smart parking the roof of the parking is covered with the solar panels. Especially during sunlight hours of 9 a.m. to 3 p.m. more energy generated during this time.

This generated energy is fed to the grid to fulfill the energy requirement.



Fig.(3)Electricity generation by solar (By placing solar panels on roof of parking)

2.2.2 Wind

Wind energy most reliable, cleanest and easy to available form of renewable form of energy. Wind turbine convert wind energy into electric energy [4].

In smart parking wind turbine is installed to convert wind energy into electrical energy and this generated energy is fed to the grid.

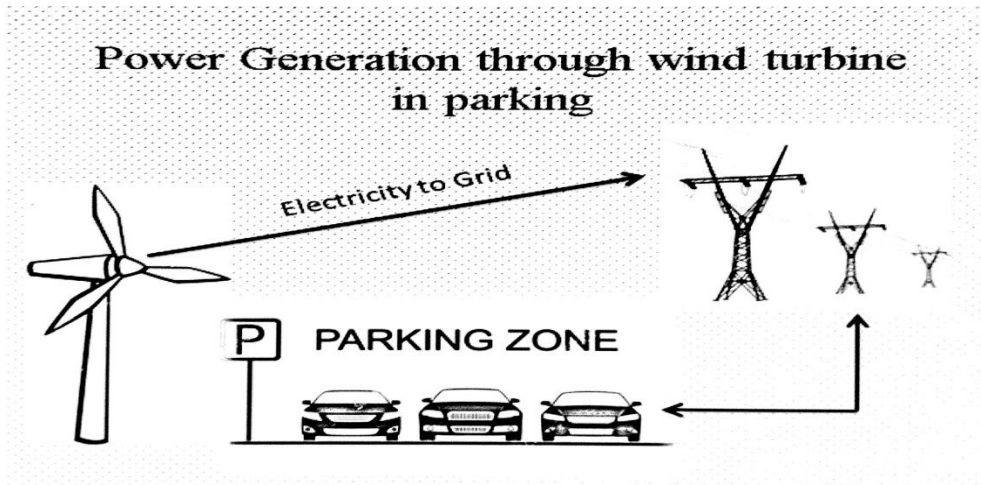

Fig.(4)Electricity generation by wind (by installing wind turbine in parking)

2.2.3 Piezo

In piezo electric electricity is generated when vehicle is pass over the speed breaker

The Kinetic energy of moving vehicles can be converted into mechanical energy of the shaft through rack and pinion mechanism [2]. This shaft is connected to the electric dynamo and it produces electrical energy

By installing piezo speed breaker in parking electrical energy is generated and this energy is fed to the grid

III BLOCK DIAGRAM

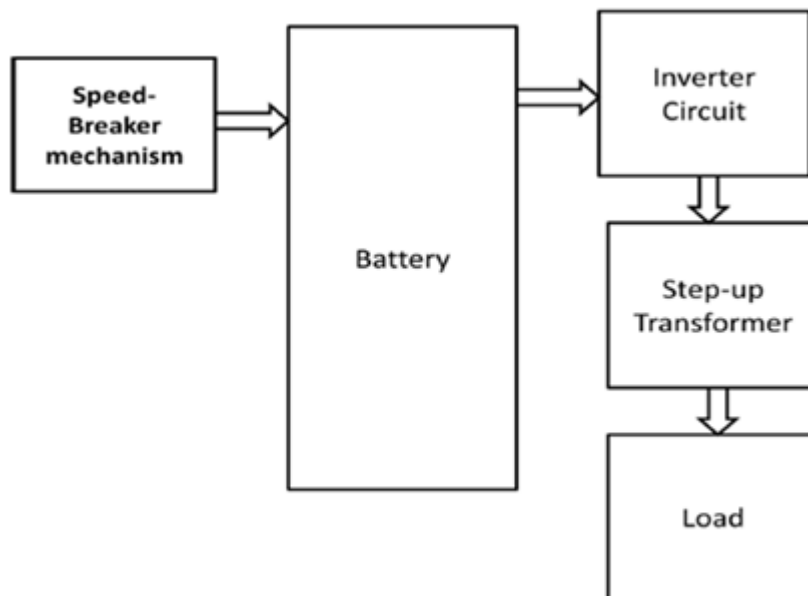

Fig.(5).Block diagram of electricity generation through Speed breaker

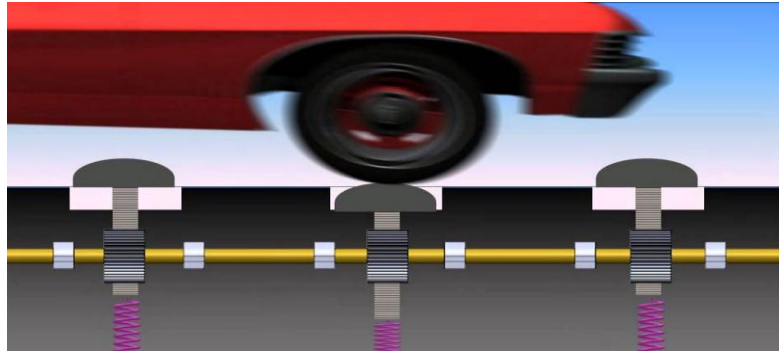

Fig.(6)electricity generation through Speed breaker(by piezo)

3.1 Energy conservation by motion sensors

To control the parking lighting automatically turns on and off whenever need and save energy

Motion sensors automatically turn on whenever they detect the motion. They are very useful for utility lighting and outdoor security, because in dark the light is needed only when peoples are present.

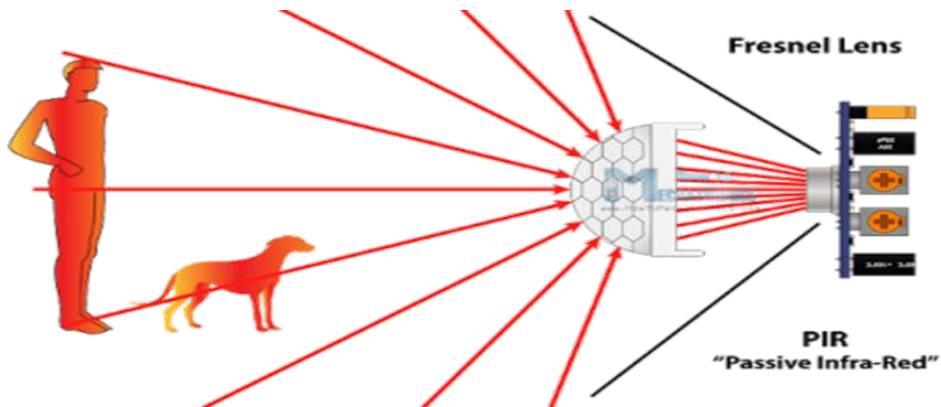

Fig.(7) passive infra-red(PIR)motion sensor forenergy conservation

3.2 Anti-theft smart Parking

In parking system automatic gate open and closing is provided by RFID. Only RFID registered vehicle is allow to enter in parking and for non- registered vehicles Master Key is use to operate parking gate. This master key is provided to authorize person to operate the parking gate.



Fig.(7)EM-18 RFID Reader Module with RFID tag for security purpose

3.3 Wireless charging

To charge electric vehicle plug is always required. In smart parking system wireless charging system is provided in parking system. In wireless charging mainly two components are required. That is primary coil and secondary coil. Primary coil is located at ground pad and secondary coil is inside in the vehicle

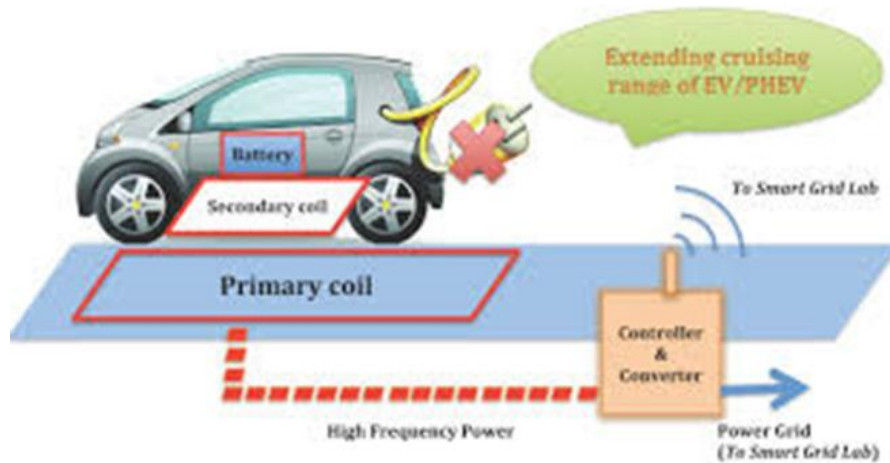

Fig.(8) wireless charging in smart parking

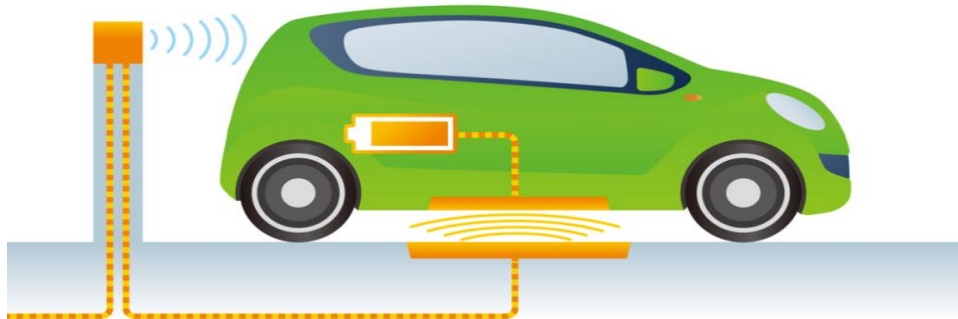

Fig.(9) wireless charging in smart parking

IV MATERIAL

SR. No	Materials	Specifications
1	Arduino Uno ATmega3p	I. Operating Voltage 5V I. Digital I/O pins:14 I. Analog input pins:6
2	Buck Boost Converter	I. Input voltage 3-34 volt I. Output voltage 4-35 volt



3	EM-18 RFID Reader Module	I. Input voltage 5 volt I. Card detect range 3-8 cm
4	Step up Transformer	I. Primary voltage 12 volt I. Secondary voltage 230 volt
5	passive infra-red(PIR)motion sensor	I. Operating Voltage Range: DC 4.5-20V

V CONCLUSION

In ordinary parking system there is no energy generation and conservation is possible but in smart parking system both generation and conservation of energy is possible which is useful.

REFERENCES

- [1]National Petroleum Council, Future Transportation Fuels Study, Infrastructure Committee, Electricity Subgroup, “Vehicle to Grid (V2G)”, Working Document of the NPC Future Transportation Fuels Study Made Available August 1, 2012
- [2]“Power Generation through Speed breaker”,Abdulrazzak Pathan, Aniket Garate , Karthikeyan N, Sonali Retharekar, Department of Industrial Electronics ,SHREERAM POLYTECHNIC AIROLI, NAVI MUMBAI – 400 708
- [3]Time of Day Tariff Structure, Omkar S. Pawaskar and Prof. Mrs. Swati. S. More
- [4]A Review of Renewable Energy Supply and Energy Efficiency Technologies,ShahrouzAbolhosseini,Almas Heshmati,JörnAltmann,Discussion Paper No.8145 ,April2014