



AUTOMATIC RAILWAY PRE-ANNOUNCING SYSTEM WITH WIRELESS COMMUNICATION

**Ms.Vidhy Khule¹, Ms.Neha Nikam², Ms. Ritu Shinde³,
Ms.Pallavi Lohar⁴, Ms. Kanchan Vakhare⁵**

*¹ Electrical ,K.K.Wagh Institute of Engineering and Research Centre
^{2,3,4,5} Electrical ,GuruGobind Singh Polytechnic Nashik*

ABSTRACT

Our country is one of the gravest countries in the world which have most serious geological disaster. Day by day the geological disaster gets worse, and endangers people's lives and property directly, affects the sustainable development of our society's economy. There appears frequently some natural phenomena such as the mountain collapse, mountain slide and so on along the line of railway, which badly threaten the traffic and transport safety of the railway. The slide and collapse can destroy the line, prevent the train from running, endanger the station, smash the station house up; destroy the railroad bridge and other facilities, cut off the tunnel, destroy the bright cave. To build a set of perfect and reliable system for monitoring and pre-alarm in long-range and real-time along railroad lines with dangerous mountains has extremely important significance. At present, the methods used for solid monitoring are mainly some traditional monitoring methods, which exist problems of low degree of automation and poor efficiency in common; since imported high- accuracy gauging device whose price is so expensive that it is unsuitable for long-time observation in field scene, and harmful for extension to popularize.

Keywords: *Automation, Sensor*

I. INTRODUCTION

The aim of the project is to develop an efficient train monitoring and protection system. A classification of accidents by their effects (consequences); e.g., head-on collisions, rear-end collisions, derailments. Head on collision; one type of train accident is when two trains collide front face with each other or train colliding on the same track from opposite ends called head on collision. Rear end collision; the other kind is when a train collides into the other that is in front of it, called a rear end collision. Derailments plain track; a train may derail on a simply straight track that may cause the train accident. Curves; derailment of a train is morecommon when there is a curve on the track

causing an accident. Junctions; a train may also get derailed on a junction, which is the place where two tracks converge into one, or one diverges into two.

Accident contributors such as train visibility advance signs, active warning, driver behavior, driver distraction and risk taking have been identified as common human factors contributors to vehicle train grade crossing accident. Factor includes highway and railway characteristic are contributing factor to accident at RLC. The environmental factors are snow, heavy rain, fog, or blowing snow, which collision the train. The three main factors contributing to accidents at RLC is basic safety engineering studies, human factor, engineering factor, and environment factor. The taxonomy of railway intersection accident contributors was created to generate hypotheses and deduction about specific cases and common patterns of accident contributors.

II. BLOCK DIAGRAM

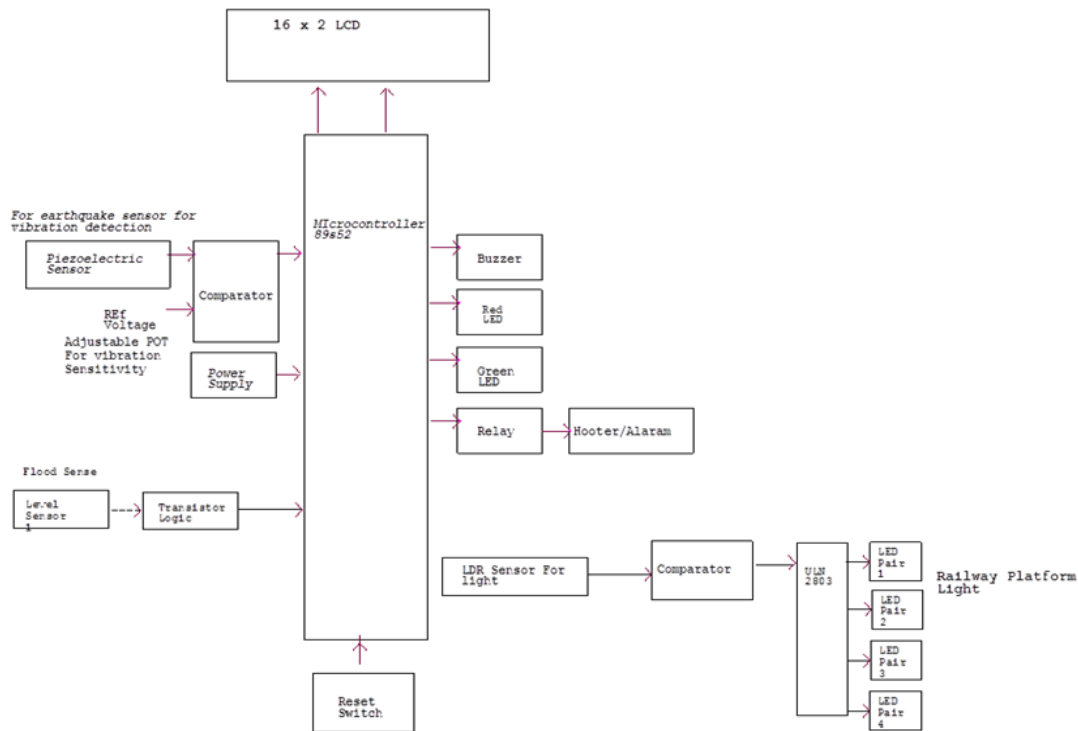

III. SYSTEM AND METHODOLOGY

The accidents at unmanned level crossings and collision of trains running on same track are the major accidents in railways which cause heavy human causality and damage to train. Hence it is proposed to develop a fail proof system to avoid such accidents. The unmanned level crossing is fitted with obstacle sensor and automatic gate closing mechanisms and Zigbee. The PC in the master control room will receive information via Zigbee from the train and continuously estimate the distance between the train and the unmanned gate. The same track and estimate

the distance between two consecutive trains running on same track and transmit this information to corresponding train. Upon receiving the information regarding the distance of previous train, the speed of the train is automatically decreased or increased or if the distance is very less the train is stopped.

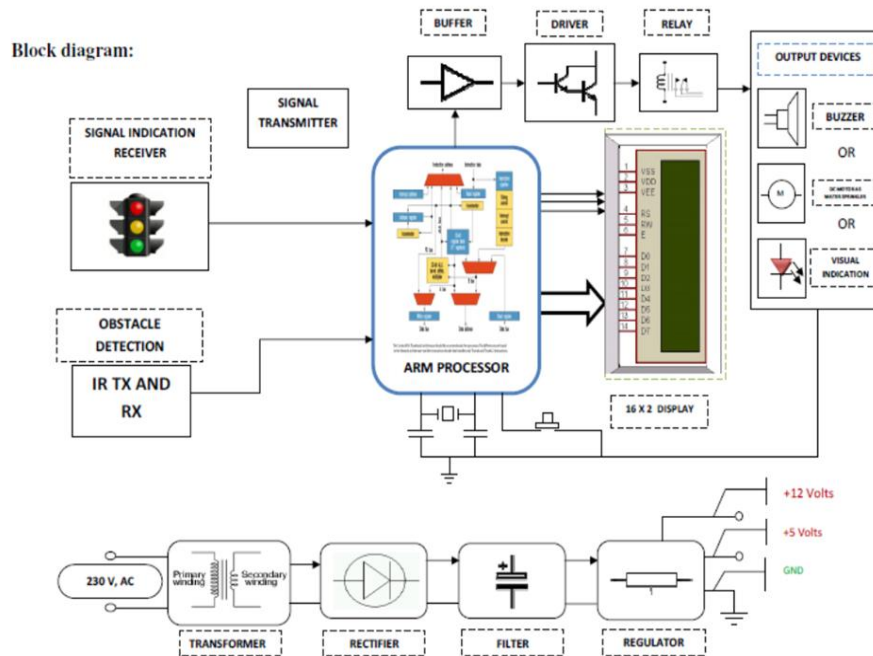

IV. ADVANTAGES.DISADVANTAGES & APPLICATIONS

Advantages:

1. This system does not create any harm to passengers.
2. It is simple to design.
3. This application is very useful in any place or area.
4. This application is easy to install and easy to operate.
5. Manpower can be saved.
6. More reliable than manual Operation.

Disadvantages:

1. One time investment of cost.

Applications:

1. Vehicle tracking system.
2. Fuel tracking system.
3. Patient Monitoring System.
4. Bio-Feedback control of robotics and applications.
5. Alert SMS.



V. CONCLUSION

Level Crossing protection systems is developed using microcontroller to give additional safety shield at manned and unmanned level crossings, through an audio-visual indication to road users. The automatic railway gate controller thus can be used in unmanned level crossings to reduce the occurrence of accidents. Since the design is completely automated it can be used in remote villages where no station master or line man is present.

REFERENCES

- [1]“Cost effective system for railway level crossing protection” konkan railway corporation limited.Special Issue on NDT of Rails *47(6) 346-353 (2005)*
- [2]R.AnujTyagi,Er. GoutamArora “synopsis on automatic railway crossing system” S.D. Institute of Technology & Management Israna-(Panipat). Evaluation of Structural and Biological systems *V, SPIE (2006)*
- [3]Richard J. Greene, John R. Yates and Eann A. Patterson, "Crack detection in rail using infrared methods", *Opt. Eng. 46, 051013, May 2007*