



MOTOR PROTECTION SYSTEM USING MODERN INTEGRATION TECHNIQUES

**Ms.Divya.R. Dhagate¹, Mr.Krishna Bhokare²,
Mr. Rushikesh Bakle³, Mr.Harshal Jadhav⁴**

^{1,2,3,4}Department of Electrical Engineering, Guru Gobind Singh Polytechnic Nashik .Maharashtra, (India)

ABSTRACT

Companies always tend to minimize their production cost &searches for an cost effective solution. We have The industrial sector is growing rapidly along with globalization. Also due to this various industrials sectors gain their control over market. For achieving of this every industry is trying to maintain their grip over competition. announced this project by putting into this consideration. There are several fluids on production floor. Certain fluid contains acids, bases, alkaline. Which reacts with sensors along with connecting leads of sensors To trouble shoot this problem, we have design a non contact type level indicator which proves to be cost effective. The major problems also Arises with poor power supply quality. Poor input power gives rise to voltage unbalance, harmonic distortion, excessive vibration, overheating, insulation failure, mechanical stressed.Also to apply an effective solution in a cheap price this project proves to be effective. This project increase overall life of motor.

Keywords: Three Phase Induction Motor, Reed Switch, Voltage unbalance, Harmonic Distortion.

I INTRODUCTION

Accurate, affordable and reliable level measuring technology is of great importance for industrial, domestic and other varieties of applications. Such applications include fuel storage, providing flood warning, in the biochemical industry and simple water level control in homes just to mention a few. The industrial era had global Impact on the world. Their generated a race between industrials sectors to become hierarchy of the globalization. At first there consist of a few industry but due to achievements of interest trade begin to grow beyond boundaries. The industrial sector is growing rapidly along with globalization. Also due to this various industrials sectors gain their control over market. For achieving of this every industry is trying to maintain their grip over competition. Companies always tend to minimize their production cost &searches for an cost effective solution.The monarchy came to an end &

gave birth to cybernetic war. To accomplish this place in this modern era a new symmetric, time sparing, less expensive drives gained demand. First the drive consisted of different power conversions including diesels, steam, etc. But due to implementation of electrical energy for drive, it showed it's advantages. In this Project we are using reed switch measuring level of all type of fluids A magnetic field (from an electromagnet or a permanent magnet) will cause the reeds to come together, thus completing an electrical circuit. The stiffness of the reeds causes them to separate, and open the circuit, when the magnetic field ceases. Another configuration contains a non-ferrous normally-closed contact that opens when the ferrous normally-open contact closes. Good electrical contact is assured by plating a thin layer of non-ferrous precious metal over the flat contact portions of the reeds; low-resistivity silver is more suitable than corrosion-resistant gold in the sealed envelope. There are also versions of reed switches with mercury "wetted" contacts. Such switches must be mounted in a particular orientation. Otherwise drops of mercury may bridge the contacts even when not activate

II BLOCK DIAGRAM

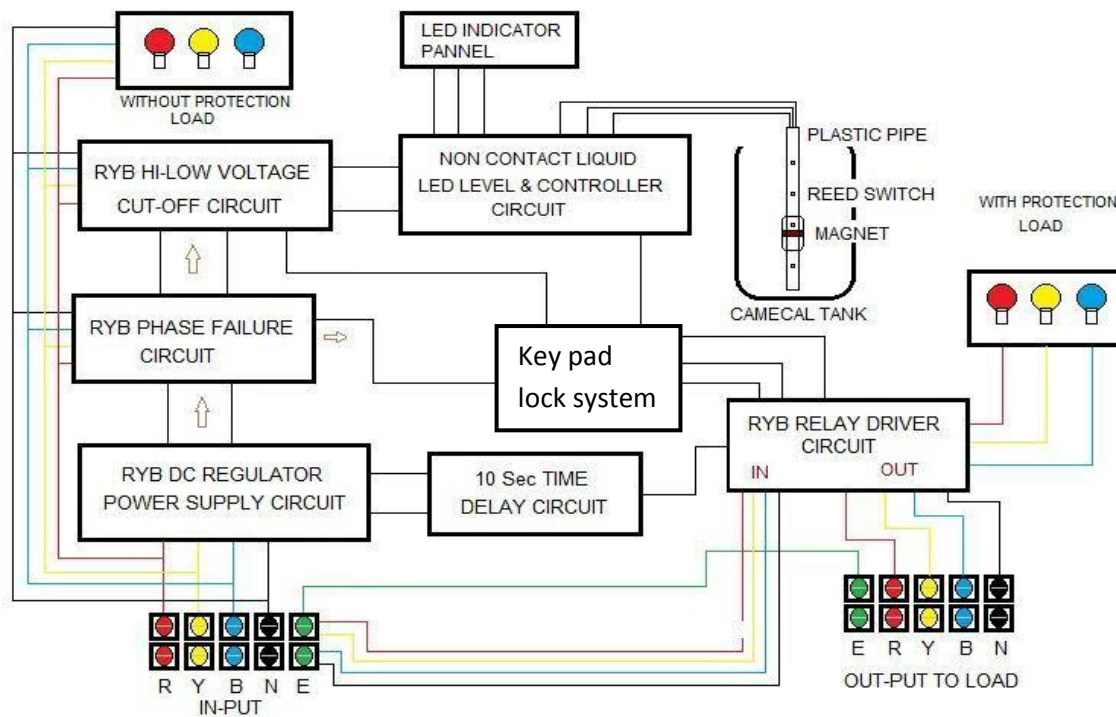

Fig.1.Block Diagram



PHASE INPUT SUPPLY

A 3 phase input supply is given to circuit. But only a few watts/hour is consumed by project, & remaining power is given to motor through contactor.

RYB DC REGULATOR POWER SUPPLY CIRCUIT

Every electronics circuit requires a DC supply for its operation. The 3 phase supply is converted into 9 V DC supply with the help of transformers, diodes, filters & regulator IC.

Component used:

1. Diode (1N 4007)
2. Capacitor (1000 micro farad 25v)
3. Regulator IC (7809 :- 9V) (7805 :-5v)

RYB PHASE FAILURE CIRCUIT

As we know that a 3 phase IM requires all the 3 phases. If in case any one phase gets disconnected then there could rise various problems consisting of voltage unbalance, harmonic distortion, overload remaining two phases, etc. To overcome this problem an "RYB PHASE FAILURE CIRCUIT" is designed which automatically cut's off the contactor if any one of phase out of 3 phases is disconnected.

RYB HI-LOW VOLTAGE CUT-OFF

In industry ,their consist of various loads & not only motors. There may arise a voltage drop or even a voltage rise in any phase. This could also give rise to various problems. Hence this circuit programs function of disconnecting the contactor when the voltage is either low or high of any phases out of 3 phases.

TIME DELAY CIRCUIT

In 3 phase supply, each phase touches o & remains negative for a specific cycle & specific time. The circuit should only work when a time greater than above stated time is required. Hence a time delay circuit of 10 sec. is designed.

NON- CONTACT LIQUID LEVEL INDICATION

For industrial applications including pharmaceutical manufacturer deals with various types of chemicals & fluids which may cause reaction with connected leads of sensors used for liquid level management.

The figure consists of q chemical tank. An industrial grade plastic pipe is used as support for float. The float is also made up of industrial grade plastic . Inside a float a small pipe larger than support pipe is fixed. To support pipe & float pipe are friction free and easy to move. The float consist of a magnet placed and whole float is sealed with 'M-seal' There are '4 read switch' each indicating different level of fluid in % .

These connections are given to 'Non - contact liquid LED level & controller circuit 'which identify level of fluid & process it.

KEY PAD LOCK SYSTEM

A keypad lock system is introduced in this system to ensure unauthorized access for the work floor w.r.t. motor system

RYB RELAY DRIVER CIRCUIT

The isolation of contactor is carried out by relay each above designed circuit separate the contactor through relay.

INDICATION BULB

WITHOUT PROTECTION LOAD

A 3 phase input connections are connected to these sets. They are used to show the variation in load of unprotected system.

WITH PROTECTION LOAD

These are actually the indication system which actually shows difference between unprotected system & our design system which uses protection

III CIRCUIT DIAGRAM

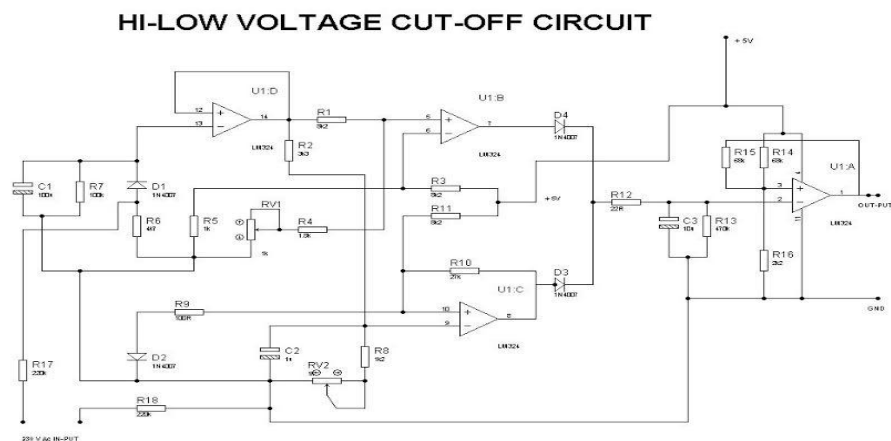

Fig.2. Circuit Diagram



IV ADVANTAGES

1. First of all the project is based on OP-AMP and switching & circuit. Hence need of embedded system and its programming is nullified.
2. It provides protection & of motor against over current hence copper losses are significantly reduced
3. It also reduces voltage unbalance and harmonic distortion
4. Also mechanical vibration are reduced.
5. It protects unauthorized access on working floor w.r.t. motor
6. This system supports both single phase and three phase motors
7. It reduces hazards of chemical reaction between workers as it reduces efforts of workers to visually inspect the level indication of various fluid used in industries.
8. The project increases overall efficiency of motors by improving supply quality .
9. It increases life pf motor by providing it with proper load conditions
10. For Conservation Of Electrical Energy
11. Ensure Increase In Life Of Motor And Drive.

V APPLICATION

- Our designed system is suitable for all ratings of motors with just some minor adjustments.
- This system can be employed at every area which consist of single phase and three phase induction motors the areas included are
 1. Chemical industry
 2. Pharmaceutical industry
 3. Process industry
 4. Textile industry
 5. Paper mills
 6. Thermal power plants
 7. Hydro-electric power plants
 8. Nuclear power plants
 9. Geo-thermal power plants



VI CONCLUSION

An initial outcome from this study indicates that most of these integrated systems are more reliable than conventional systems and may reduce energy costs, Energy Conservation in Motor and it also increase its efficiency and Life of Motor. Different Power quality problems like voltage unbalance, Harmonic Distortion, Overcurrent etc can be solve or reduce by using a simple integrated circuit which is a combination of Non contact Type Level Indication of Fluids, High-low voltage cut off, Phase Failure Circuit & Key pad Lock System

With the development of this system 100% Motor Protection can be possible with any type of load.

REFERENCES

- [1] S. Yio, P. B. B Ruffin, F. T. S. Yu, and S. Yin, *Fiber Optic Sensors*, Marcel Dekker, New York, NY, USA, 2008.
- [2] J. Rheims, J. Köser, and T. Wriedt, "Refractive-index measurements in the near-IR using an Abbe refractometer," *Measurement Science and Technology*, vol. 8, no. 6, pp. 601–605, 1997.
- [3] M. Daimon and A. Masumura, "Measurement of the refractive index of distilled water from the near-infrared region to the 6 Journal of Sensors ultraviolet region," *Applied Optics*, vol. 46, no. 18, pp. 3811–3820, 2007.
- [4] S. Nemoto, "Measurement of the refractive index of liquid using laser beam displacement," *Applied Optics*, vol. 31, no. 31, pp. 6690–6694, 1992.
- [5] F. Docchio, S. Corini, M. Perini, and R. S. Gasana, "A simple and reliable system for measuring the refractive index of liquids using a position-sensitive detector," *IEEE Transactions on Instrumentation and Measurement*, vol. 44, no. 1, pp. 68–70, 1995.
- [6] P. Nath, H. K. Singh, P. Datta, and K. C. Sarma, "All-fiber optic sensor for measurement of liquid refractive index," *Sensors and Actuators A: Physical*, vol. 148, no. 1, pp. 16–18, 2008.
- [7] C.-B. Kim and C. B. Su, "Measurement of the refractive index of liquids at 1.3 and 1.5 micron using a fibre optic Fresnel ratio meter," *Measurement Science and Technology*, vol. 15, no. 9, pp. 1683–1686, 2004.