

# IMPROVEMENT OF DYNAMIC PERFORMANCE OF INTERCONNECTED POWER SYSTEMS WITH STATIC SYNCHRONOUS SERIES COMPENSATOR

Youssef Mobarak<sup>1</sup>, Ahmed M. Elnoby<sup>2</sup>

<sup>1</sup>Electrical Engineering Department, Faculty of Engineering, Rabigh, King Abdulaziz University, Saudi Arabia

<sup>1,2</sup>Electrical Engineering Department, Faculty of Energy Engineering, Aswan University, Egypt

## ABSTRACT

*It is well known that the automatic generation control AGC system is employed to compensate the power system load disturbances which cause power system frequency and tie-line power deviations. The conventional AGC depends essentially of mechanical speed governor system. The speed governor system is slow and it needs maintenance and change. With advent of power electronic switches, Flexible AC Transmission System FACTS devices or controllers are applied to compensate quickly the load disturbances whereupon the frequency and tie-line power deviation can be deleted. The FACTS devices used in this paper is Static Synchronous Series Compensator SSSC. The structure of SSSC involves Voltage Source Inverter VSI and coupling transformer that are connected in series with tie-line between power system areas to inject source voltage of variable magnitude and phase angle. The control system of SSSC device is to modulate and update the exchange power between SSSC circuit and power system to compensate the load disturbance in power system areas. The application of SSSC stabilizer for power system frequency and tie-line power stabilization due to load excursion occurred in power system. The studied power system is simulated using Matlab Simulink Package. The two-area power system performances with SSSC device in terms of area frequency deviations and tie-line power responses are obtained. A comparison between the system performances with SSSC stabilizer in sense of undershoot and settling time.*

**Keywords:** *Load Frequency Control, Static Synchronous Series Compensator, Speed Governor, Economic Dispatch, and Load Sharing*

## I. INTRODUCTION

The concept of load frequency control LFC has been developed to maintain a constant frequency and to regulate the tie line flows. It regulates the frequency deviations and tie line interchanges between different areas that are interconnected with each other. The most widely employed controller is the conventional proportional integral PI controller [1]-[3]. The optimal control is quite often impractical for the implementation because it is a function of all the states of the system but in practice, all the states may not be available in [4]-[5]. The inaccessible states or missing states are required to be estimated. In variable structure or sliding mode control system the structure of the control law may change during the course of action in accordance with the state, output or error measurement

in [6]-[7]. Stability is the ability of an electric power system, for return the system to steady state conditions or given initial operating condition after being subjected to small and large different disturbances [8]-[10]. FACTS devices provide strategic benefits for improving transmission system management in terms of better utilization of existing transmission assets, increased transmission system reliability and availability, increased dynamic and transient grid stability, increased quality of supply for sensitive industries, and enabling environmental benefits [11]. The need for more efficient electricity systems management has given rise to innovative technologies in power generation and transmission. The central technology of FACTS involves high power electronics, a variety of thyristor devices, microelectronics, communications and advanced control centers [12-13].

Arrangement capacitive recompense was acquainted decades back with drop a part of the receptive line impedance and there-by expansion the transmittable force [14]. Late advancement of force hardware presents the utilization of adaptable air conditioning transmission framework FACTS controllers in force frameworks [15]. Thusly, inside the FACTS activity, it has been showed that variable arrangement remuneration is profoundly viable in both controlling force stream in the lines and in enhancing dependability [16]. The voltage sourced converter based arrangement compensator, called SSSC gives the virtual recompense of transmission line impedance by infusing the controllable voltage in arrangement with the transmission line. The capacity of SSSC to work in capacitive and also inductive mode makes it exceptionally compelling in controlling the force stream of the framework [17]. SSSC is one of the imperative parts of FACTS family which can be introduced in arrangement in the transmission lines. With the capacity to transform its reactance trademark from capacitive to inductive, the SSSC is exceptionally compelling in controlling force stream in force frameworks [18]. An assistant settling sign can likewise be superimposed on the force stream control capacity of the SSSC in order to enhance power framework wavering steadiness [19]. The applications of SSSC for force wavering damping, steadiness upgrade and recurrence adjustment can be found in a few references [20]-[22]. As of late, new computerized reasoning based methodologies have been proposed to outline a FACTS-based supplementary damping controller. These methodologies incorporate molecule swarm improvement [23]-[25], hereditary calculation [26], differential advancement [27], and multi-objective evolutionary calculation [28].

The applications incorporate sparing burden dispatching, force framework stabilizers PSS, and so forth. The proposed controller has been connected and tried under diverse aggravations for a multi-machine power framework. The framework comprises of three generators partitioned into two subsystems and are joined through an inertia. For the outline reason, MATLAB/Simulink model of the force framework with SSSC controller is created. Reproduction results are exhibited at diverse working conditions and under different unsettling influences to demonstrate the viability of the proposed controller. The results demonstrate that the proposed SSSC-based controller can enhance the voltage profile and transient solidness of the test framework more productive than the ordinary lead-slack controller of above gadgets [29]-[31]. In view of this the main objectives of the present work are: To develop the two area Simulink model of hydrothermal system under load following. To develop the model of SSSC, and to compare the improvement of dynamic performance of the system with SSSC. The rest of the paper is organized as follows: A general overview on FACTS systems is given firstly. Dynamic mathematical model considered in this work. Describes the mathematical model of SSSC to be incorporated into the system. Demonstrates the results and discussions and some conclusions are presented finally.

## II. STUDIED SYSTEM

The schematic of an SSSC, located in series with the tie-line between the interconnected areas can be applied to stabilize the area frequency oscillations by high speed control of the tie-line power through interconnection as shown in Fig. (1). Also, represent by a series connected voltage source  $V_s$  along with a transformer leakage reactance  $X_s$ . The SSSC controllable parameter is  $V_s$ , which in fact represents the magnitude of injected voltage. Fig. (2) represents the phasor diagram of the system taking into account the operating conditions of SSSC.

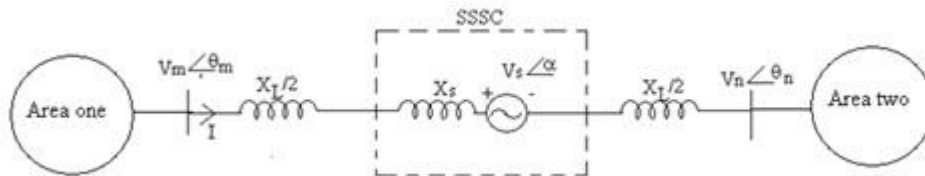

Fig. 1.Simplified Two-Area Studied System with SSSC Device

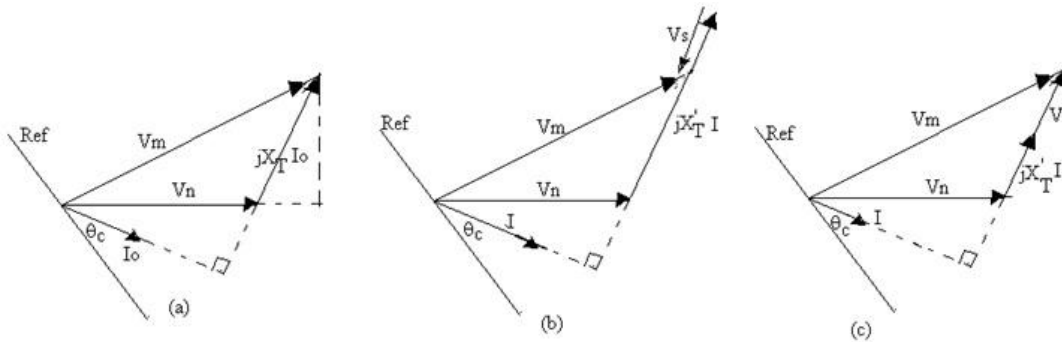

Fig. 2. Phasor Diagram (a)  $V_s=0$ , (b)  $V_s$  Lagging  $I$  by  $90^\circ$  (c)  $V_s$  Leading  $I$  by  $90^\circ$

The voltage phasor diagram is drawn in the three states without SSSC, with lagging, and leading). The effect of connecting SSSC in tie line power flow is formulated and derived in mathematical form as when  $V_s=0$ , the current  $I_o$  of the system can be written as:

$$I_o = \frac{V_m - V_n}{jX_T} \tag{1}$$

Where  $X_T = X_L + X_S$ .

The phase angle of the current can be expressed as:

$$\theta_c = \tan^{-1} \left( \frac{V_n \cos \theta_n - V_m \cos \theta_m}{V_m \sin \theta_m - V_n \sin \theta_n} \right) \tag{2}$$

From the Eqn. (1) can be expressed in a generalized form as:

$$I = \frac{V_m - V_s - V_n}{jX_T} = \frac{V_m - V_n}{jX_T} + \frac{-V_s}{jX_T} = I_o + \Delta I \tag{3}$$

The term  $\Delta I$  is an additional current due to SSSC voltage  $V_s$ . The complex power flow from bus m to bus n can be written as  $S_{mn} = V_m I^* = S_{mno} + \Delta S_{mn} = P_{mn} + jQ_{mn}$ , which implies:

$$P_{mn} + jQ_{mn} = (P_{mno} + \Delta P_{mn}) + j(Q_{mno} + \Delta Q_{mn}) \tag{4}$$

Where  $P_{mno}$  and  $Q_{mno}$  are the real and reactive power flow respectively when  $V_s=0$ , the real power flow caused by SSSC voltage is given by:

$$P_{SSC} = \frac{V_m V_s}{X_T} \sin(\theta_m - \alpha) \tag{5}$$

When  $V_s$  lags the current by  $90^\circ$ , ( $\alpha = \theta_c - 90^\circ$ )  $\Delta P_m$  can be written as:

$$P_{SSC} = \frac{V_m V_s}{X_T} \cos(\theta_m - \theta_c) \tag{6}$$

From fig (1) the term  $\cos(\theta_m - \theta_c)$  in eqn (6) can be written as:

$$\cos(\theta_m - \theta_c) = \frac{V_n}{V_m} \cos(\theta_n - \theta_c) \tag{7}$$

Then:

$$\cos(\theta_n - \theta_c) = \frac{V_m \sin(\theta_{mn})}{\sqrt{V_n^2 + V_c^2 - 2V_n V_c \cos(\theta_{mn})}} \tag{8}$$

Where  $\theta_{mn} = \theta_m - \theta_n$

Also, using the above Equations can be modified as follows:

$$P_{SSSC} = \frac{V_m V_n}{X_T} \sin \theta_{mn} \frac{V_s}{\sqrt{V_n^2 + V_c^2 - 2V_n V_c \cos \theta_{mn}}} \tag{9}$$

At last the power flow between buses m and n in both senses are given by:

$$P_{mn} = -P_{mno} \frac{V_m V_n}{X_T} \sin \theta_{mn} \left( 1 + \frac{V_s}{\sqrt{V_n^2 + V_c^2 - 2V_n V_c \cos \theta_{mn}}} \right) = P_{tie} + P_{SSSC} \tag{10}$$

Linearizing Eqn. (10) about an operating point it can be written as:

$$\Delta P_{mn} = \frac{V_m V_n}{X_T} \cos \theta_{mn} (\Delta \theta_m - \Delta \theta_n) + \frac{V_m V_n}{X_T} \sin \theta_{mn} * \frac{\Delta V_s}{\sqrt{V_n^2 + V_c^2 - 2V_n V_c \cos \theta_{mn}}} \tag{11}$$

$$\Delta P_{mn} = \Delta P_{tie} + \Delta P_{SSSC} \tag{12}$$

Where:

$$\Delta P_{tie} = \frac{V_m V_n}{X_T} \cos \theta_{mn} (\Delta \theta_m - \Delta \theta_n) \tag{13}$$

$$\Delta P_{SSSC} = \frac{V_m V_n}{X_T} \sin \theta_{mn} * \frac{\Delta V_s}{\sqrt{V_n^2 + V_c^2 - 2V_n V_c \cos \theta_{mn}}} \tag{14}$$

Based on Eqn. (14) it can be observed that by varying the SSSC voltage  $V_s$ , the output power of SSSC can be controlled which will in turn control the frequency and tie line deviations.

The two-area power system model consists of two of one area systems connected through tie line. Each area consists of three first-order transfer functions, modeling the system turbine, governor, and generator power system. However, the incremental tie line power is calculated as follows:

$$\Delta P_{tie} = \frac{2\pi T_{12}}{s} (\Delta F_1(s) - \Delta F_2(s)) \tag{15}$$

Where:  $T_{12} = \frac{V_1 V_2}{X_{12}} \cos(\delta_1 - \delta_2) T$  (16)

$X_{12}$  is tie line reactance,  $V_1, V_2, \delta_1$  and  $\delta_2$  are voltages and angles of area buses

The block diagram of two-area power system is built and illustrated as fig. (3). From the above equations it is shown that there are his steady state errors of frequency deviations  $\Delta F_1, \Delta F_2$  and tie power deviation  $\Delta P_{tie}$  following a change in loads.. In other words, if there is a change in area-1 load, there should be supplementary control action only in area-1 and not in area-2. The control signal is known as Area Control Error ACE. The ACE for area-1 and area-2 can be defined as:

$$ACE_1 = B_1 \Delta F_1 + \Delta P_{tie} \tag{17}$$

$$ACE_2 = B_2 \Delta F_2 + a_{12} \Delta P_{tie} \tag{18}$$

Where  $B_1$  and  $B_2$  are frequency biases for area-1 and area-2 respectively

Application of tie line frequency bias control in terms of ACE in two-area power system is depicted in fig. (3). AC interconnected power system is subjected to a large load rapid change, system frequency may be severely disturbed and becomes oscillatory. To stabilize the frequency oscillations, application of the SSSC to stabilize the frequency of oscillations in an interconnected power system is investigated. The SSSC is located in series with the tie-line between any interconnected areas as shown in fig (3). Application of SSSC to provide an active power control facility for stabilization of frequency oscillations in an interconnected power system is proposed. The control system of SSSC device for LFC system stabilization due to load disturbance in terms of damping of frequency deviations of two areas and tie-line power. The SSSC is superior to the conventional frequency control system, i.e. governor, in terms of a high-speed performance. The control signal to SSSC device is scaled frequency deviation of one area summed with scaled tie-line power deviation. However, the SSSC is modeled by first order transfer function  $(1/(1+t_{SSSC}s))$ . The output signal from SSSC device is the active power deviation summed with tie-line power deviation and sent to two areas at summation junction of power system model as shown in fig. (3). It is noted that the output signal from SSSC stabilizer is the active power injected to tie-line to compensate the load deviation disturbance.

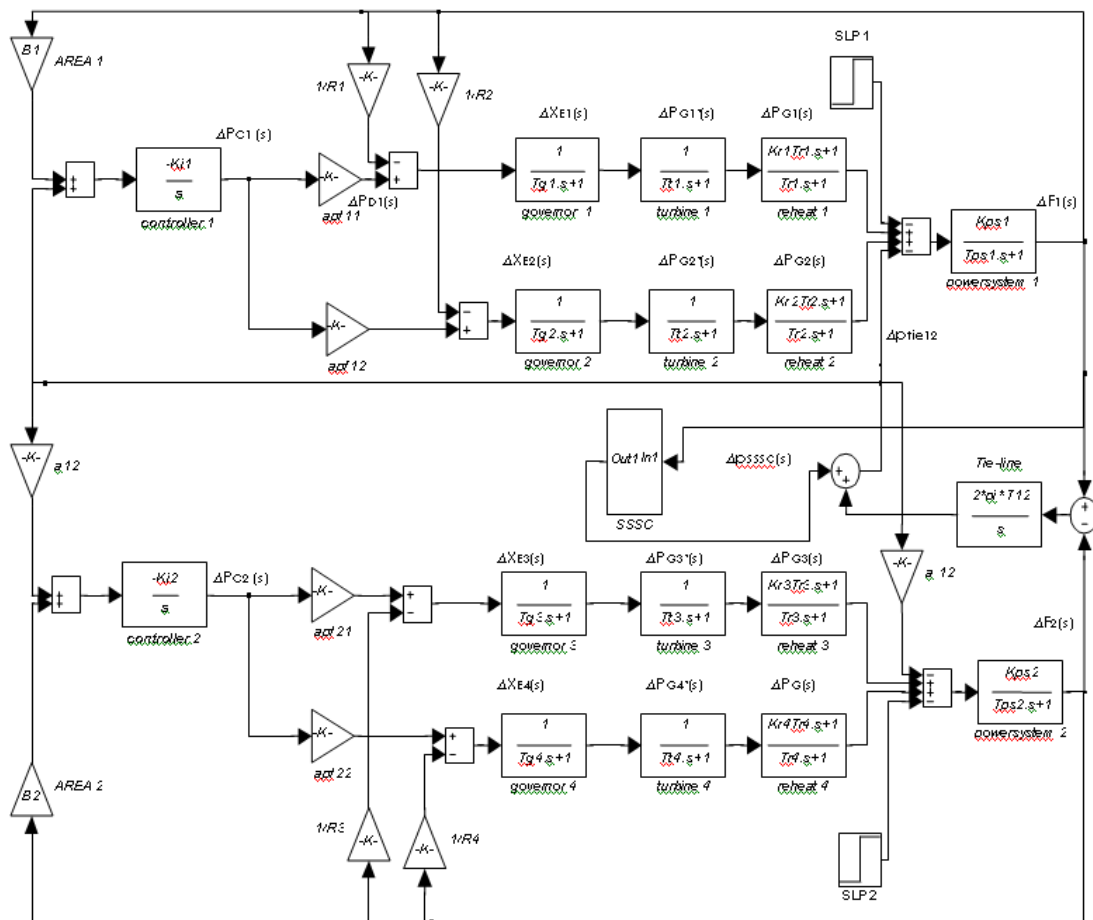
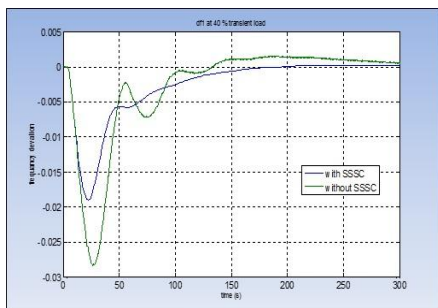

Fig. 3 Two-Area Studied System with SSSC Device Controls

III. RESULTS AND DISCUSSIONS

The above two-area power system with SSSC stabilizer is simulated using Matlab Simulink software Package. However the values of gains of SSSC stabilizer of frequency and tie-line power deviations  $G_1$  and  $G_2$  are selected as -10 and 0.5 respectively. Also the time constant of SSSC block  $T_{SSSC}$  is 0.03 sec. The studied system is subjected to different disturbances which can be described as follows: The step load perturbation  $\Delta P_D$  of 10% is applied in area #1 the frequency oscillations and tie-line power flow deviations are obtained in fig. (4). System performances with and without SSSC stabilizer in terms of deviations of frequencies of each area and deviations of tie-line power flows i.e.  $dF_1$ ,  $dF_2$ , and  $dP_{tie}$ . It is noted that with SSSC stabilizer, the system response in terms of frequency deviations of two areas and tie-line power deviations are better in sense of overshoot, settling time. Also, the Effect of load disturbance  $\Delta P_D$  of area-1 of 40% value: With and without SSSC stabilizer, the two-area power system states responses are shown in fig. (5) in terms of deviations of frequencies of each area and deviations of tie-line power flows. It is noticed that the system responses in terms of frequency deviations of two areas and tie-line power deviations are better with SSSC stabilizer in sense of overshoot, settling time.



(a)

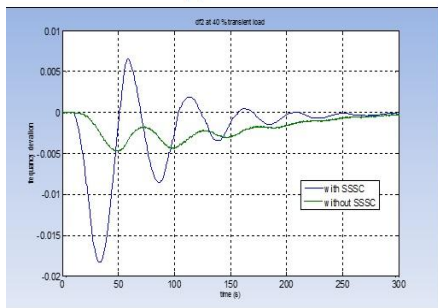

(b)

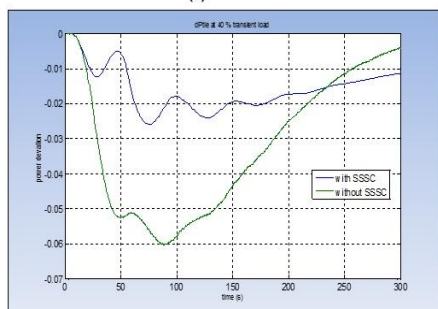

(c)

**Fig. 4 Effect of load disturbance  $\Delta P_D$  at area-1 of 10% on variable system parameters ( $\Delta F_1$ ,  $\Delta F_2$ , and  $\Delta P_{tie}$ ) with and without SSSC device**



(a)

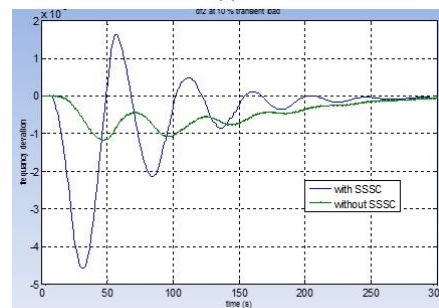

(b)

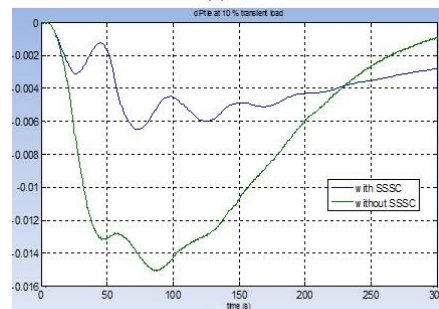

(c)

**Fig. 5 Effect of load disturbance  $\Delta P_D$  at area-1 of 40% on variable system parameters ( $\Delta F_1$ ,  $\Delta F_2$ , and  $\Delta P_{tie}$ ) with and without SSSC device**

To study the robustness of the proposed SSSC devices with system parameters variations, the effect of system parameters change on the system performance. The scale factor  $G_1$  of frequency deviation used to generate the input signal with scaled tie-line power deviation for SSSC block is changed to study the robustness of SSSC stabilizer to restore the system states after load disturbances. The values of frequency deviation scale factor is changed from -4 to -15 and the system responses in terms of frequency deviation of each area and tie-line power deviation due to load disturbance in area one of 40% value are shown in fig. (6). From the above response figures it is noticed that the system responses in terms of frequency deviations of two areas and tie-line power deviations due to system parameters variations in terms of frequency deviation scale factors are robust with SSSC stabilizer in sense of overshoot, settling time. The values of SSSC time constant  $T_{SSC}$  is changed from .01 to 1 sec and the system responses in terms of frequency deviation of each area and tie-line power deviation due to load disturbance in area one of 40% value are shown in fig. (7). The system responses in terms of frequency deviations of two areas and tie-line power deviations due to system parameters variations in terms of SSSC stabilizer block time constant  $T_{SSC}$  are compared in sense of overshoot, settling time.

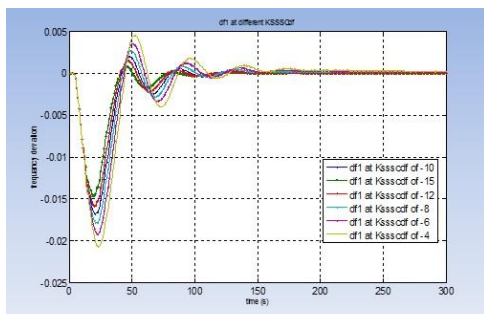

(A)

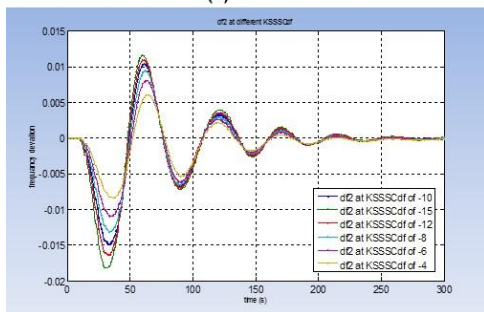

(b)

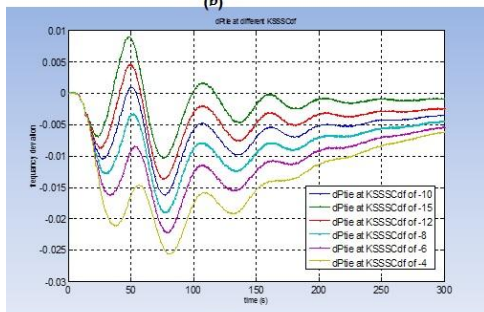

(c)

Fig. 6 Effect of scale factor  $K_{SSC}$  parameters at area-1 of 40% on variable system parameters ( $\Delta F_1$ ,  $\Delta F_2$ , and  $\Delta P_{tie}$ ) with SSSC device

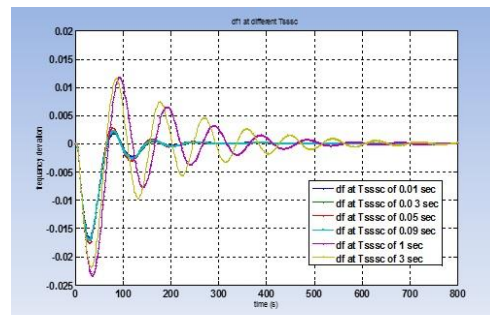

(a)

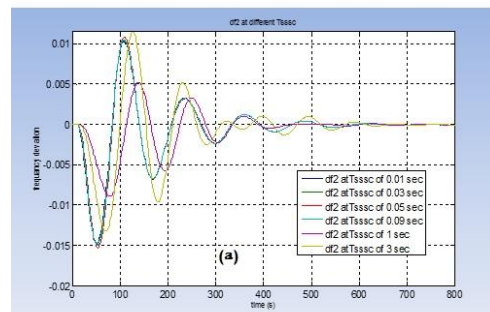

(b)

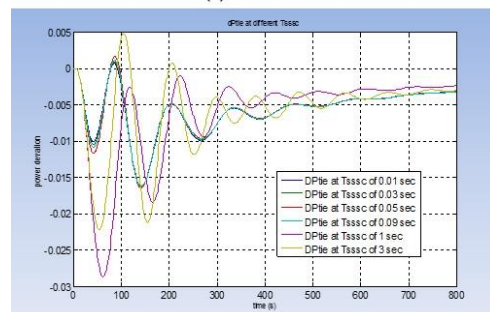

(c)

Fig. 7 Effect of time constant  $T_{SSC}$  parameters at area-1 of 40% on variable system parameters ( $\Delta F_1$ ,  $\Delta F_2$ , and  $\Delta P_{tie}$ ) with SSSC device

## IV. CONCLUSIONS

Modeling of AGC system in block diagram is established in one-area and two-area interconnected thermal plant power system. Also the construction of SSSC devices are described. Application of SSSC controller for stabilization of AGC system is investigated. The two-area interconnected power system model including the control system of SSSC controller is developed. The studied system is tested using Matlab Simulink package. The digital simulation results due to different load disturbances of 10% to 40% value in terms of area frequency and tie-line power deviations proves the effectiveness and powerful of SSSC device via quickly damping the oscillations and restoring the normal power system frequency and tie-line power. Also, the effect of control parameters variation of SSSC control system gain block value and time constant of SSSC block on system performance shows that the proposed system with SSSC device is robustness and system performance still better. The results indicate that the SSSC controller improves effectively the damping of the oscillations and reduces the settling time and overshoot as compared to PI controller only. Therefore, the two-area power system with SSSC stabilizer is preferred and is fast compared to governor speed controller only. Where the governor speed is a mechanical system whereupon it needs large time to response and make an action to restore and stabilize the system states. The effect of system parameters and SSSC time constant variations are studied and obtained. The results show that the proposed load frequency control system with SSSC is robust for system parameters variations.

## REFERENCE

- [1] Devender Kumar, Balwinder Singh Surjan, "Transient Stability of a Multi Machine Power System ", International Journal of Engineering and Advanced Technology (IJEAT), Vol.2, Issue-4, April 2013.
- [2] Prechanon Kumkratug, Panthep Laohachai, "Direct Method of Transient Stability Assessment of a Power System with a SSSC," Journal of Computers, Vol.2, No.8, pp. 77- 82, 2007.
- [3] Youssef A. Mobarak, Voltage collapse prediction for Egyptian interconnected electrical grid EIEG, International Journal on Electrical Engineering and Informatics, Vol. 7, No.1, pp. 79-88, March 2015.
- [4] W. Du, X. Wu, H. F. Wang, and R. Dunn, "Feasibility study to damp power system multi-mode oscillations by using a single FACTS device," Int. J. Electr. Power Energy Syst., Vol. 32. No. 6, pp. 645-655, 2010.
- [5] Youssef A. Mobarak, and Mahmoud M. Hussein, Voltage instability and voltage collapse as influenced by cold inrush current, ICGST International Journal on Automatic Control and System Engineering, Vol. 12, Issue 1, pp. 21-30, June 2012.
- [6] J.Vivekananthan, R.Karthick, " Voltage Stability Improvement and Reduce Power System Losses by Bacterial Foraging Optimization Based Location of Facts Devices", International Electrical Engineering Journal (IEEJ) Vol. 4 No. 1, pp. 1034-1040, 2013.
- [7] Y. A. Mobarak, "Fault duration for voltage instability and voltage collapse initiation as influenced by generator voltage magnitudes GVM", Journal of Engineering Sciences, Egypt, Vol. 40, No. 3, pp.846-866, May 2012.
- [8] Y. L. Karnavas and D. P. Papadopoulos, "AGC for autonomous power system using combined intelligent techniques," International Journal of Electric Power System Research, vol. 62, pp. 225–239, 2002.



- [9] Y. Ba and W. Li, "A Simulation Scheme for AGC Relevant Studies," IEEE Transactions on Power Systems, Vol. 28, No. 4, pp. 3621–3628, 2013..
- [10] A. B. Gamal, M. Z. El-Sadek, Y. A. Mobarak, "Applicable values of turbines speed governor regulation", 10th International Middle East Power Systems Conference, pp. 39-42, December 13-15, 2005.
- [11] A. M. Elnoby, et.al. "Robust Technique LFC of Two-Area Power System with Dynamic Performance of Combined SMES and SSSC Control", International Journal of Advances in Engineering & Technology (IJAET), Vol. 8 Issue 2, pp. 46-58, Apr. 2015.
- [12] Gaber El-Saady, et.al., "A New Robust Technique LFC of Multi-Area Power System Using SMES", International Journal of Automation and Systems, Vol. 1, No. 2, pp. 56-60, April 2013.
- [13] Abdullah Alshehri, Ahmad Hussain, and Youssef A. Mobarak, Energy-conversion measures in the industries of Saudi Arabia and development of methodology for certification of energy personnel in the kingdom, Energy Policy, Vol. 64, pp. 203-208, 2014.
- [14] B. T. Ramakrishna Rao et al , " Power System Stability Enhancement Using Fact Devices", Int. Journal of Engineering Research and Applications, Vol. 4, Issue 4, pp.339-344, 2014.
- [15] Molla Shahadat Hossain Lipu, Tahia Fahrin Karim, "Effectiveness of FACTS controllers and HVDC transmissions for improving power system stability and increasing power transmission capability , " International Journal of Energy and Power Engineering; Vol. 2, No.4: pp.154-163, 2013.
- [16] Sandeep Gupta, R. K. Tripathi (2010) "Voltage Stability Improvement in Power Systems using Facts Controllers: State-of-the- Art Review". IEEE transactions on Power System, pp.I-8.
- [17] Viresh kumar G. Mathad, ey.al.," Review on Comparison of FACTS Controllers for Power System Stability Enhancement ", International Journal of Scientific and Research, Vol. 3, Issue 3, March 2013.
- [18] Satvinder Singh, et.aj., "Transient Stability Enhancement of Multi-Machine System Using FACTS Controllers" International Journal of Engineering Science and Innovative Technology (IJESIT) Vol. 2, Issue 2, March 2013
- [19] Ghahremani, E., Kamwa,"Optimal placement of multiple-type FACTS devices to maximize power system load ability using a generic graphical user interface", IEEE Trans. Power Syst., Vol.28, No.2, pp. 764–778, 3013.
- [20] Ghahremani, E., Kamwa, "Maximizing transmission capacity through a minimum set of distributed multi-type FACTS". IEEE PES General Meeting 2012, pp. 523–528.
- [21] Pradeepkumar S. Mahapure , Prof. A. R. Soman, "Comparison of FACTS Devices for Power System Transient Stability Improvement", International Journal of Innovative Research In Electrical, Electronics, Instrumentation And Control Engineering Vol. 2, Issue 6, June 2014.
- [22] MrinalRanjan and B. Vedik, " Optimal Location of FACTS Devices in a Power System by Means of Sensitivity Analysis", Trends in Electrical and Computer Engineering TECE, Vol. 1, No. 1, pp1-9, 2011.
- [23] M.Srinivasa Rao et al.," Transient Stability Performance Analysis of Power System Using Facts Devices" , Int. Journal of Engineering Research and Applications, Vol. 4, Issue 2, February 2014, pp.250-256.
- [24] ManojNinoria , Nitin Saxena, " Modeling, Analysis and Comparison of Various FACTS Devices in Power System " International Journal of Electrical, Electronics and Computer Engineering, Vol. 2, No. 2, pp. 34-39, 2013.

- [25] G. Shabib, Y. A. Mobarak, M. H. El-Ahmar, “Combined SVC and SSSC controllers for power system transient stability improvement”, 13th International Middle East Power Systems Conference, pp. 573-577, December 21-23, 2009.
- [26] G. Madhusudhana Rao, Dr. B.V Sanker Ram, B. Sampath Kumar, “TCSC designed optimal power Flow Using genetic algorithm”, International Journal of Engineering Science and Technology Vol. 2, No.9, 2010, pp.4342-4349.
- [27] Akhilesh A. Nimje, et.al.“Enhanced power transfer Capability using SSSC”, Journal of Mechanical Engineering Research Vol. 3, No. 2, pp. 48-56, 2011.
- [28] L. Jebaraj, C. ChristoherAsirRajan, S. Sakthivel, “Incorporation of SSSC and SVC Devices for Real Power and Voltage stability Limit Enhancement through Shuffled Frog Leaping Algorithm under Stressed Conditions”, European Journal of Scientific Research, Vol.79 No.1, pp.119-132. 2012.
- [29] M.Bongiorno ,J.Svensson, and L.Angquist, “Single-phase VSC based SSSC for sub synchronous resonance damping,” IEEE Trans. Power Del., Vol. 23, No. 3, pp. 1544–1552, 2011.
- [30] S. Padma, Dr. R. Lakshmipathi,” Static Synchronous Series Compensator (SSSC) with Superconducting Magnetic Energy Storage (SMES) for the Enhancement of Transient Stability in Multi- Area System”, ACEEE Int. J. on Control System and Instrumentation, Vol. 02, No. 01., 2011
- [31] Sandeep Bhongade, H.O. Gupta, BarjeevTyagi “Effect of SMES unit in multi-area Automatic generation control scheme suitable in restructured power system” International Journal of Distributed Energy Resources, Vol. 7, No. 2, April-June 2011, pp. 149-165.