

# AUTOMATED WATER DISTRIBUTION SYSTEM USING PLC AND SCADA

**T. Baranidharan<sup>1</sup>, A.Chinnadurai<sup>2</sup>, R.M.Gowri<sup>3</sup>, J. Karthikeyan<sup>4</sup>.**

*<sup>1</sup>Associate Professor, <sup>2,3,4</sup>UG Students, EIE, K.S.Rangasamy College of Technology,  
Tiruchengode, (India)*

## ABSTRACT

*This proposed automated water distribution system is used to distribute the municipal water equally to all street pipe line. So that everyone will get the equal amount of water. The set point is fixed for each pipe line. The water from the storage tank is measured with the help of level sensor. Flow sensor measures the flow rate of the water. Solenoid valve is used to open and close the valve automatically. If the flow rate reaches its set point, Solenoid will be turned OFF and it will be turned ON after 24 hours later. Here we also identify the water theft accurately during the distribution time period. This system consists of PLC and SCADA. PLC is used to control the distribution of water. SCADA is one of the emerging technologies which are used for complete monitoring. The overall system is connected to PLC with the help of RS-232 cable. PLC gives the signal to the solenoid valve according to the set point written in the program.*

**Keywords:** *Flow sensor, Level sensor, PLC, SCADA, Solenoid valve*

## I INTRODUCTION

Water is important resource for all the livings in the earth. In that some people are not getting the sufficient amount of water because of unequal distribution of water. So only we implement this project. This project is used to distributing the water equally. So that everyone gets the equal amount of water. It also used to prevent the water theft during the distribution period. In previous method, person in charge will go to that place and open the valve for a particular time period. Once the time over again the in charge person will go to the same place and close the valve. It is wastage of time. The proposed system is fully automated. Here human work and time is reduced. The water wastages such as leakages, mankind laziness and operating error can be avoided.

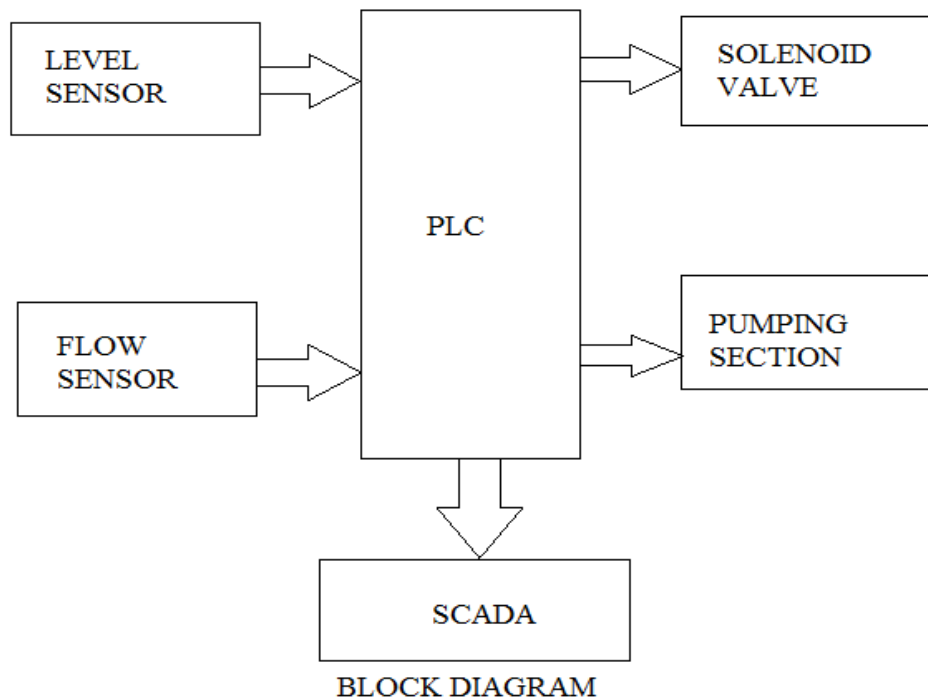

## II PREVIOUS WORK

The water wastage is due to many reasons such as wastage of water, human laziness, operator fault etc. There is also problem of indiscretion of water supply i.e. the list of water supply is not secure. Now-a-days, water storage and distribution system, controlling temperature, pressure and for every stage for measuring and analyzing. We can't able to identify the robbery in urban drinking water supply. Water flow control is impossible and not controlling. The water supply systems are part of the urban structure which must assure the continuity of the water distribution, the water quality control and the displaying. In existing system, urban water is supplied to the home with the help of some human power. The person to take the charge will go to the place and then open the valve to that exact area. Once the time is over the person will go again to that place and close the valve immediately. This type of operation needs human power. This is excess of time and to go to that place and comeback often. Also the people may take extra water for their personal use with the help of motor. Due to this many people will not receive sufficient water for their use. Water is the basic and important needs of the human life. The water theft prevented only when any public inform the officials about the theft.

## III METHODOLOGY

Level sensor is used to sense the amount of water level present in the storage tank. 24V DC supply is given to the water. The buzzer indicator is connected to the level sensor. It will then connect to the PLC.

It is shown in the below figure 2. If the water capacity reaches 80 percentages in the storage tank the buzzer will give the alarm signal. The pump will be turned off with the help of PLC. Once the water is not sufficient (if it below 80%) in the tank the pump will be turned on. If the water level once attains its 80% the overall system is started.

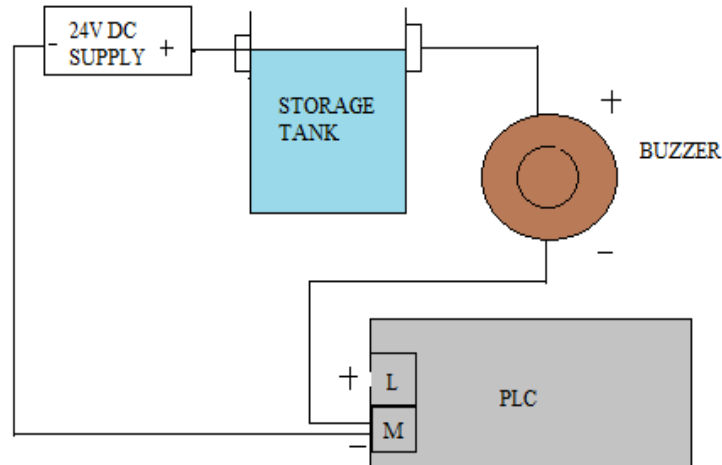

**Fig.No.2 Level Measurement.**

Solenoid valve is a two port valve. It will be used to turn on and off condition. In this project three solenoid valves are used. 230V supply is given to the main solenoid valve. PLC output is connected to the solenoid valve with the help of RS232 cable. The output from the PLC in the range of 24V DC. So it is necessary to give switch function using relay to on and off the solenoid valve. If the water level in the storage tank is reached the 80%, main solenoid valve is automatically turned on. The set point is fixed for solenoid valve2 and solenoid valve3. If anyone one of its valve or both the valve attains the set point the solenoid valve is turned off. The valve will be turned on after 24 hours later. 2W-025-08(G1/4) (Shown in Figure.No3) normally closed solenoid valve is used to control the flow rate.



**Fig.No.3 2W-025-08(G1/4) Solenoid valve**

Flow sensor is used to measure the flow rate of the water. YF-S201 type of flow sensor is used (Shown in figure 4). Flow sensor contains pin wheel in its. Pinwheel contains 6 teeth. The pulse output is comes from the pin wheel sensor. If the teeth rotate at one time, it will give the pulse output according to the specification of the flow sensor. From the pulse output easily measure the amount of water passed through the pipe. The pulse is converted to voltage

with the help of Hall Effect sensor. Flow sensor output is in the range of 5V DC. So it is necessary to give signal conditioning. Optocoupler is used to amplifying signal.



- Red wire : +5V
- Black wire : GND
- Yellow wire : PWM output.

**Fig.No.4 YF-S201 Flow sensor**

**IV PROPOSED SYSTEM**

The hardware layout of the proposed system is shown in figure 5. The overall distribution process is monitored in PC. Pumping section is connected to PLC. If the water level below the set point the pump is automatically ON with the help of PLC. Checking the level in storage tank is the first process. If the level attains the set point overall system is started. The water is flow through the pump when the main solenoid valve opens. The flow rate is measured with the help of pulse output from the flow sensor. The people can get water until the set point reaches. Once the water usage attains the set point the particular solenoid valve is automatically close.

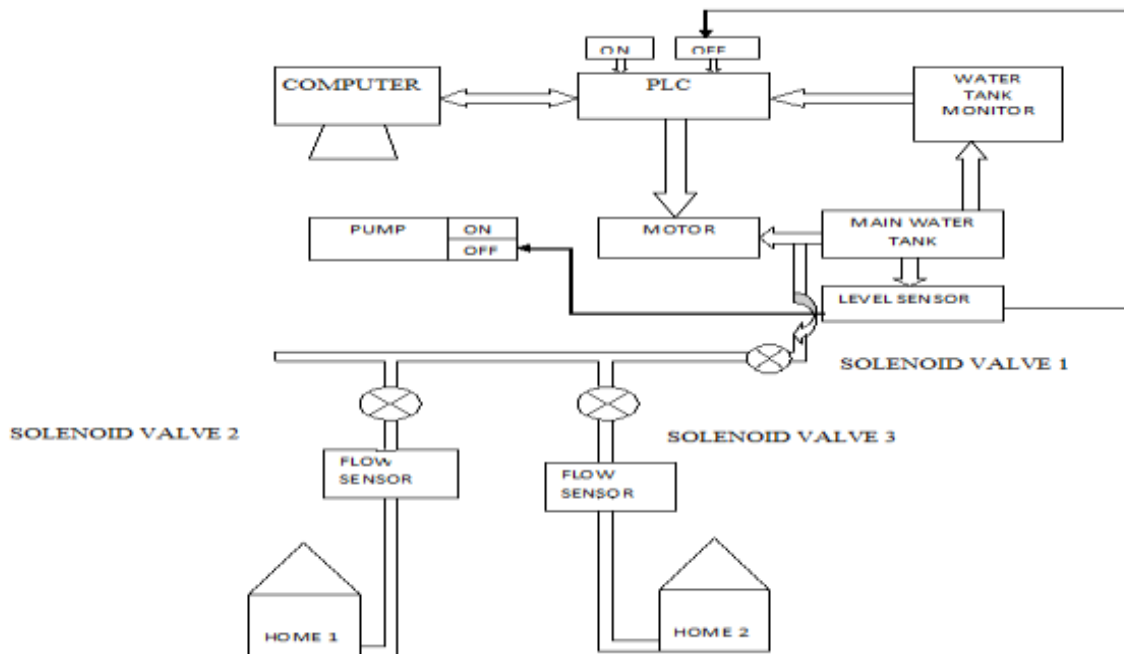

**Fig.No.5 Proposed System**

**V PUMPING SECTION**

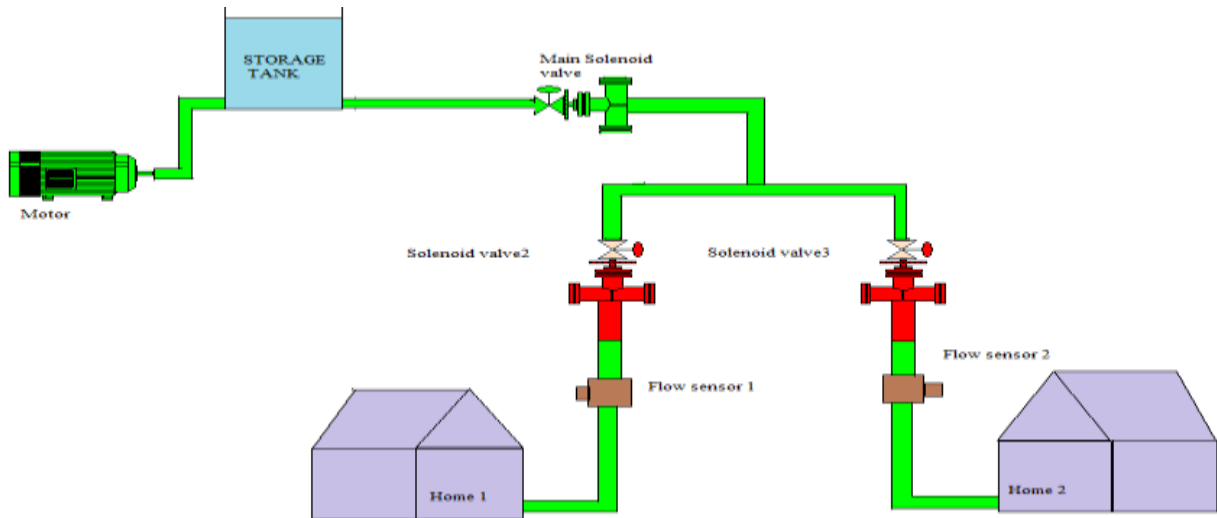

**Fig.No.6 Pumping Section**

Once the main solenoid valve gets opened, the water flow through the pump. The water level in the storage tank gets decreased. We can measure the water level using the sensor attached to the storage tank. When the water decreased below 80% the pump is on.

**VI WIRING DIAGRAM**

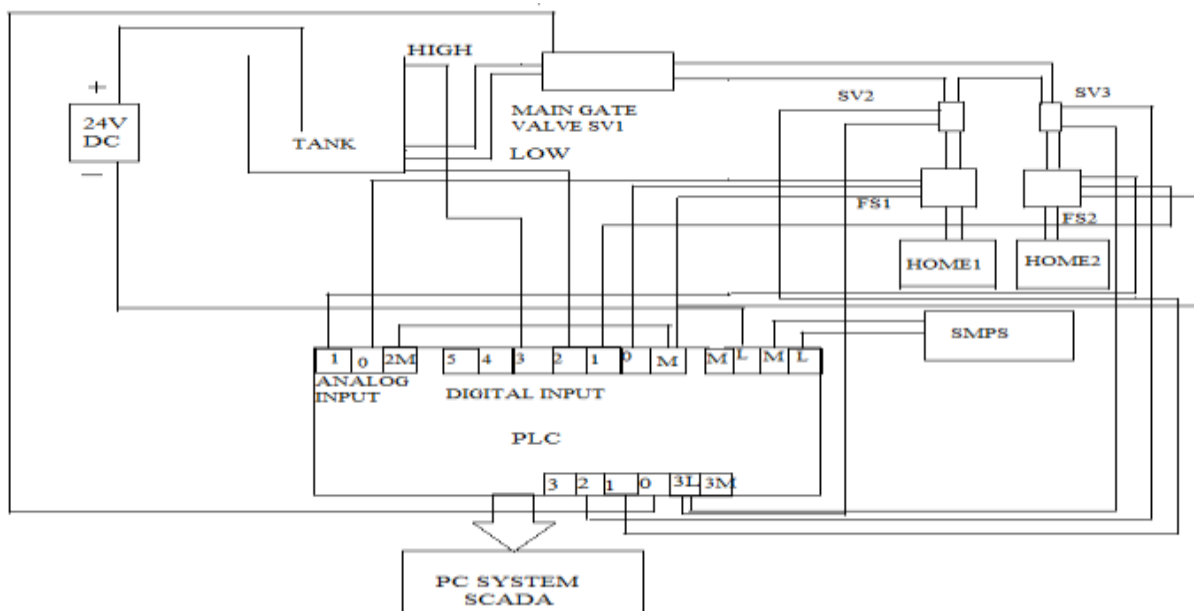

**Fig no. 6 Wiring Diagram**

## VII CONCLUSION

The automation of water distribution system eliminates water wastage. Automation system provides continuous water flow according to the set point. This project is automatic so it reduces lots of man power. The automation implemented in water distribution system ensures to avoid wastage of water and reduces time. And also we can completely avoid the water theft in the pipelines. So that people could get equal share of water. This system is excellent and cost effective to prevent the drinking water from the theft.

## REFERENCES

1. RamleelaKhare, Dr.Filliperodrigues, & E. Mela; “ Automation of water distribution plant”, International journal of Research in Engineering and Advanced Technology, Vol.2, pp:1-6, 2014.
2. Aunbhanchal, Ketakee Dagade, Shubhangi Tamhane, Kiran Pawar, & Paradnya Ghadge; “Automated water supply system & Water theft Identification Using PLC and SCADA”, International journal of Engineering Research and Applications, Vol.4, Issue.4, pp: 67-69, April 2014.
3. Ayamal Alinhussein & Mohammed Adedalati; “ A Supervisory Control and Data Acquisition (SCADA) for water pumping station of GAZA”, The Islamic University Journal, Vol.19, pp:303-321, 2011.
4. J.P. Shridharanyaa, Jagadeesan.A, & Lavanya. A; “Theft Identification and Automated Water Supply System Using Embedded Technology”, International Journal of Advanced Research in Electrical, Electronics and Instrumentation Engineering, Vol.2, pp:1-7, 2013.
5. Bhawarkr.N.B, Pande.D.P, Sonone.R.S, Pandit.P.A & Patil.P.D; “Literature Review for Automted Water Supply with Monitoring the Performance System”, International Journal of Current Engineering and Technology, Vol.4, pp:1-4, 2014.
6. Gowri Shankar; “ Control of Boiler Operation Using PLC& SCADA”, International Journal of Multi Conference of Engineering and Computer Scientists, Vol.2, pp:1-6, 2008.
7. Gaikwad Sonali Ashok; “Water Anti-theft and Quality Monitoring System by Using PLC & SCADA”, International Journal of Electrical and Electronics Engineering Research, Vol.3, Issue.2, pp:355-364, June, 2013.
8. Eswaran .P,& Aswin Kumar; “ Conceptual Design and Development of Water Metering System for Multiple family Residential Buildings”, International Journal of Advanced Computer Research, Vol.2, No.4, Issue. 6, December, 2012.
9. Shinya Ito and Kenji Yoshigoe; “Performance Evaluation of Consumed energy- Type-Aware Routing (Cetar) for Wireless Sensor Networks”, International Journal of Wireless & Mobile Networks (IJWMN), Vol.1, No 2,pp. 90-101, November 2009.
10. Dr. Shuchita Upadhayaya & Charu Gandhi; “Quality of Service Routing in Mobile Ad Hoc Networks Using Location and Energy Parameters”, International Journal of Wireless & Mobile Networks (IJWMN), Vol.1, No 2, pp. 139-147, November 2009.